

NERLITE® DOME

Available In Three Colors



Uniform Lighting Solution

Microscan's wide range of NERLITE products can illuminate any part or mark for successful machine vision and auto ID applications.

Dome illuminators are an economical source of diffused, uniform light. Their large, solid angle of illumination supports imaging of curved, shiny or bumpy surfaces. They are a cost-effective alternative to NERLITE CDI illuminators for applications not requiring an on-axis lighting component.

Dome: At a Glance

- Economical and widely-used general purpose designs
- Easily integrated
- Continuous or strobed diffused LED illumination

Illumination Example:

Object

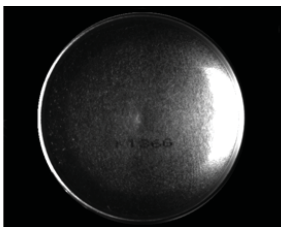

Resulting Image

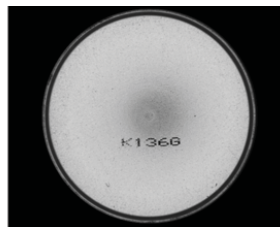

Bottom of aerosol can: Uniform illumination of concave surface results in contrast against printed characters.

For more information on this product, visit www.microscan.com.

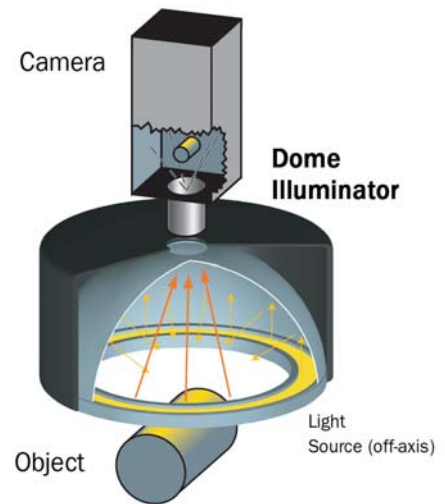

Application Examples

- Illuminate diffused or specular, flat or curved surfaces
- CD/DVD label inspection
- Inspection of surfaces for contaminants (particles, residues)

MICROSCAN®

NERLITE® DOME SPECIFICATIONS AND OPTIONS

DOME 150

DESCRIPTION	nm/K	CONT. CURRENT	STROBE CURRENT	LUX
DOME-150, Red Continuous	636 nm	80 mA		950
DOME-150, Red Strobe	636 nm		1.6 A pk	9500
DOME-150, White Continuous	6500 K	160 mA		2270
DOME-150, White Strobe	6500 K		3.2 A pk	22700
DOME-150, Blue Continuous	470 nm	160 mA		1960

Light Aperture: 4" (102 mm) diameter

Weight: 18 oz. (510 g)

Dimensions: Ø 6.19" (157.3 mm) x D 3.28" (83.3 mm)

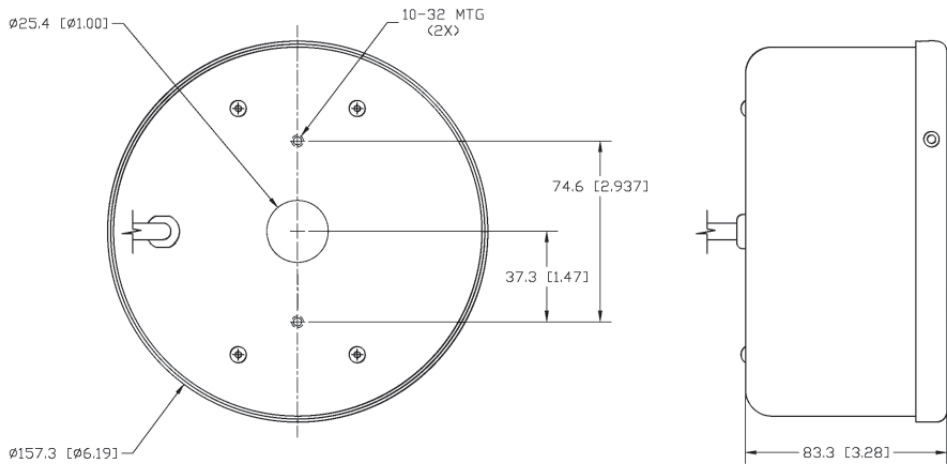

ENVIRONMENTAL

Operating Temperature: 0° to 40° C (32° to 104° F)

Storage Temperature: 0° to 50° C (32° to 122° F)

Humidity: up to 95% (non-condensing)

LIGHTING PARAMETERS

Light Aperture Defined: Area of light output from the coaxial illuminator.

LIGHT SOURCE

Type: High output LEDs

Light Output: Lux (lumens per square meter)

Expected Life: 50,000 hours (Red LEDs)

Expected Life: 10,000 hours (Blue, White LEDs)

Eye Safety: EN 60825-1: Class 1 (Red, White LEDs); Class 2 (Blue LEDs)

CONNECTOR

Type: 15 ft. (4.5 m) integrated cable with flying leads

ELECTRICAL

Power (Continuous Models): 24 VDC +/- 1%

Power (Strobe Models): 1 ms max. pulse width, 6% max duty cycle, use of NERLITE NL-200 Series Lighting Controller is required.

CE COMPLIANT

ISO CERTIFICATION

Certified ISO 9001:2008 Quality Management System

©2011 Microscan Systems, Inc. SP051B 02/11

Microscan Applications Engineering is available to assist with evaluations. Results may vary depending on symbol quality. **Warranty**—One year limited warranty on parts and labor. Free extended 3 year warranty upon online product registration.

MICROSCAN®

Microscan Systems Inc.

Tel 425 226 5700 / 800 251 7711

Fax 425 226 8250

Microscan Europe

Tel 31 172 423360 / Fax 31 172 423366

Microscan Asia Pacific

Tel 65 6846 1214 / Fax 65 6846 4641

www.microscan.com

Product Information: info@microscan.com

Auto ID Support: helpdesk@microscan.com

Vision Support: visionsupport@microscan.com

NERLITE Support: nerlitesupport@microscan.com