

# Quick Start Guide

## QX-870 Industrial Raster Scanner



**MICROSCAN.**

P/N 83-110870 Rev D

### FREE EXTENDED WARRANTY OFFER

[www.microscan.com/3year](http://www.microscan.com/3year)

#### Standard Warranty: One Year

All Microscan products are backed by a one-year standard warranty. Full warranty details are online at [www.microscan.com/warranty](http://www.microscan.com/warranty).

#### Extended Warranty: Three Years

Register this product online with Microscan to receive complete extended warranty coverage for three years.

#### LIMITED TIME OFFER: ACT NOW!

To receive a FREE extended warranty, product MUST be registered by the end-use installation facility within four months of the date of manufacture. Online registration is available at [www.microscan.com/3year](http://www.microscan.com/3year).

## Step 1 — Check Hardware

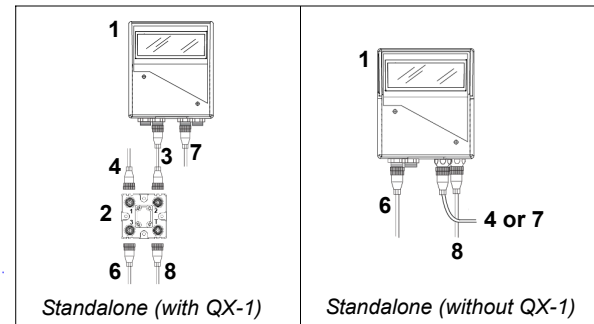

Hardware Required

**Caution:** Be sure that all connections are secure **BEFORE** applying power. Always power down **BEFORE** disconnecting any cables.

Item	Description	Part Number
1	QX-870 Industrial Raster Scanner	FIS-0870-XXXXG
2	QX-1 Interface Device	98-000103-02
3	QX Cordset, Common, M12 12-pin Plug to M12 12-pin Socket, 1 m	61-000162-01
4	QX Cordset, Host, Serial, M12 12-pin Plug to DB9, 1 m	61-000152-01
5	QX Cordset, Host, Serial, M12 12-pin Socket to DB9, 1 m	61-000153-01
6	QX Power Supply, M12 12-pin Socket, 1.3 m	97-000003-01
7	QX Cordset, Host, Ethernet, M12 8-pin Plug to RJ45, 1 m	61-000160-01
8	QX Photo Sensor, M12 4-pin Plug, NPN, Dark On, 2 m	99-000020-02

**Note:** Additional cordsets and accessories are available in the Microscan Product Pricing Catalog.

## Step 2 — Connect the System

**Important:** When connecting Ultra-Lock cordsets to the QX-870 and QX-1, align the pins first and then push the connector into place. Do not twist the connectors, as this will bend the pins.

**Important:** Do not attempt to power more than four scanners with a single power supply in a daisy chain configuration. Add a QX-1 and one power supply for every four additional scanners in the daisy chain.

#### RS-232

1. Connect the Serial Communication Cable from "A" on the QX-870 to "2" on the QX-1.
2. Connect the host cable from "1" on the QX-1 to the host computer.
3. Connect the photo sensor to "T" on the QX-1.
4. Connect the power supply to "3" on the QX-1.
5. Plug in the power supply.

#### Ethernet

**Important:** Configure Ethernet-enabled readers off-line and then connect to network when ready for dynamic use.

1. Connect the Ethernet Cable from "B" on the QX-870 to the network.
2. Connect the power supply to "A" on the QX-870.
3. Plug in the power supply.

## Step 3 — Position Scanner

1. Place a test symbol in a location with as little ambient light as possible.
2. Position the scanner at the focal distance used in your application.
3. Align the test symbol with the scanner's field of view.
4. Tip the scanner relative to the test symbol to avoid glare from specular reflection.

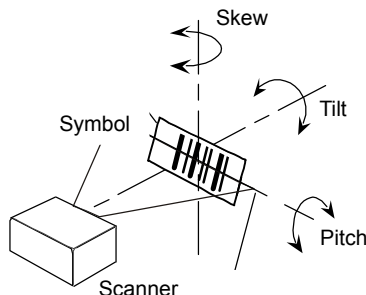

Maximum skew, tilt, and pitch:  $\pm 30^\circ$

## Step 4 — Install ESP

ESP Software can be found on the Microscan Tools CD that is packaged with the QX-870.

1. Follow the prompts to install ESP from the CD.
2. Click on the ESP icon to run the program.



**Note:** ESP can also be installed from the **Download Center** at [www.microscan.com](http://www.microscan.com).

Refer to the *QX-870 Industrial Raster Scanner User's Manual* for detailed information about using ESP to configure the QX-870.

## Step 5 — Select Model

When you start ESP, the model menu will appear:

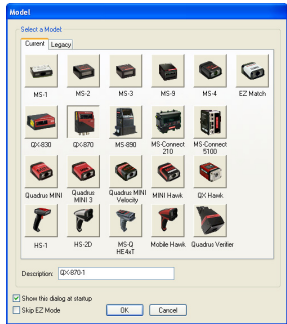

1. Click the button showing the QX-870.
2. Click **OK**.

**Note:** You can also simply double-click the button showing your scanner to make your selection.

3. Click **Yes** when this dialog appears:

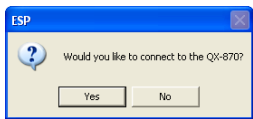

**Note:** If you need to select another model later, click the **Switch Model** button near the top of the screen or use **Model > New Model** in the menu toolbar.

## Step 6 — Connect

### RS-232

To connect using the Connection Wizard:

- Click **Connect** on the menu toolbar, and then select **Connection Wizard**.
- Select **RS-232**.
- Configure RS-232 settings as required by the application, and click **Connect**.

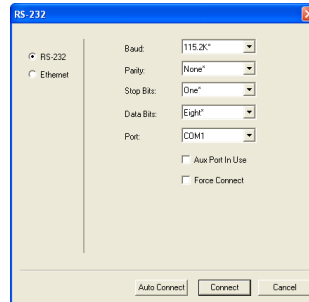

- When a connection is established, the green indicator in the status bar at the bottom right of the screen will be visible:

QX-870-1 QX-870 **CONNECTED** Point-to-Point COM1 115.2K : N : 8 : 1

**Important:** The scanner is in **Continuous Read Mode** by default. For best connection results, be sure that no decodable symbols are within the scanner's field of view while attempting to connect.

## Step 6 — Connect (cont.)

### Ethernet TCP/IP

To connect using the Connection Wizard:

- Click **Connect** on the menu toolbar, and then select **Connection Wizard**.
- Select **Ethernet**.
- Configure Ethernet settings as required by the application, and click **Connect**.

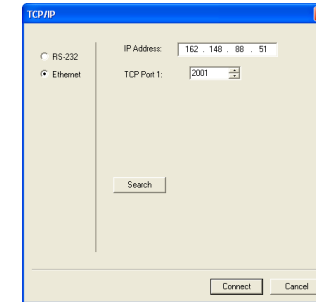

- When a connection is established, the green indicator in the status bar at the bottom right of the screen will be visible.

**Important:** The scanner is in **Continuous Read Mode** by default. For best connection results, be sure that no decodable symbols are within the scanner's field of view while attempting to connect.

## Step 6 — Connect (cont.)

### Ethernet TCP/IP (cont.)

When the QX-870 is connected, incoming symbol data can be displayed in the **Terminal**, as shown below.

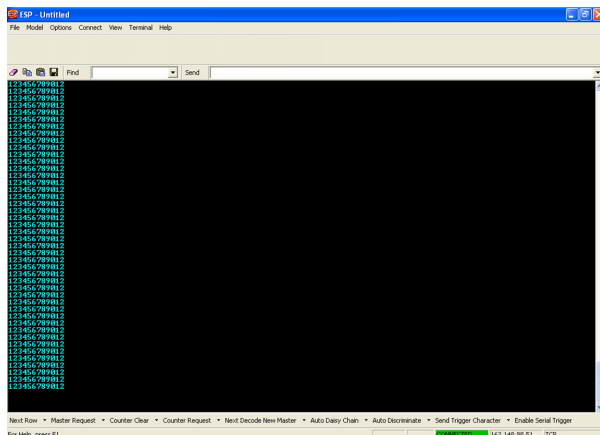

## Step 7 — Test Read Rate

**Read Rate** indicates the number or percentage of successful decodes per second achieved by the scanner.

1. Click the **Test** button in ESP's **EZ Mode** to start the Read Rate test.

Symbol data and read rate percentage information should appear in the **Symbol Information** table. The Read Rate LEDs on the side of the QX-870 will indicate the percentage of successful decodes per second.

2. Click **Stop** to end the Read Rate test.

**Note:** Read Rate can also be tested using the **Read Rate** interface in **Utilities**.

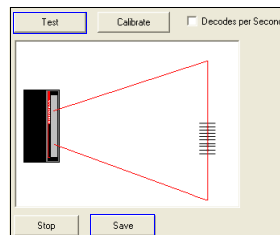

Refer to the *QX-870 Industrial Raster Scanner User's Manual* for information about how to test read rate using serial commands or the scanner's EZ button.

## Step 8 — Configure and Save

Click the **App Mode** button to make configuration changes to the scanner.



The following modes are accessible by clicking the buttons at the top of the screen:

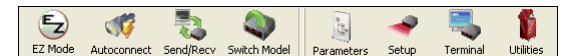

- Click the **EZ Mode** button to return to EZ Mode.
- Click the **Autoconnect** button to establish communications.
- Click the **Send/Recv** button to send or receive commands.
- Click the **Switch Model** button to open the model menu, or to return to the previous model.
- Click the **Parameters** button to show the tabbed tree control views.
- Click the **Setup** button to show the tabbed interface views.
- Click the **Terminal** button to display decoded symbol data and to send serial commands.
- Click the **Utilities** button to access Read Rate, Counters, Device Control, Differences from Default, Master Database, Digital Bar Code, and Firmware.

For further details, see **Microscan ESP Help** in the dropdown Help menu.