

MICROSCAN®

HS-2D Handheld Reader User's Manual



P/N 83-100002 Rev A

Copyright and Disclaimer

Copyright ©2011
Microscan Systems, Inc.,
1201 S.W. 7th Street, Renton, WA, U.S.A. 98057
(425) 226-5700 FAX: (425) 226-8682

ISO 9001 Certified
Issued by TÜV USA

All rights reserved. The information contained herein is proprietary and is provided solely for the purpose of allowing customers to operate and/or service Microscan manufactured equipment and is not to be released, reproduced, or used for any other purpose without written permission of Microscan.

Throughout this manual, trademarked names might be used. We state herein that we are using the names to the benefit of the trademark owner, with no intention of infringement.

Windows® Operating System is a registered trademark of Microsoft Corporation.

Disclaimer

The information and specifications described in this manual are subject to change without notice.

Latest Manual Version

For the latest version of this manual, see the Download Center on our web site at:
www.microscan.com.

Technical Support

For technical support, email: helpdesk@microscan.com.

Microscan Systems, Inc.

Renton Headquarters

1201 S.W. 7th St.
Renton, WA 98057-1213
USA
Tel: 425.226.5700 / 800.762.1149
Fax: 425.226.8250

Nashua Office

486 Amherst St.
Nashua, NH 03063
USA
Tel: 603.598.8400
Fax: 603.577.5947

Microscan Europe

Tel: 011 31 172 423360
Fax: 011 31 172 423366

Microscan Asia Pacific

Tel: 65 6846 1214
Fax: 65 6846 4641

Microscan Limited Warranty Statement and Exclusions

What Is Covered?

Microscan Systems Inc. warrants to the original purchaser that products manufactured by it will be free from defects in material and workmanship under normal use and service for a period of one year from the date of shipment. This warranty is specifically limited to, at Microscan's sole option, repair or replacement with a functionally equivalent unit and return without charge for service or return freight.

What Is Excluded?

This limited warranty specifically excludes the following: (1) Any products or parts that have been subject to misuse, neglect, accident, unauthorized repair, improper installation, or abnormal conditions or operations; (2) Any products or parts that have been transferred by the original purchaser; (3) Customer misadjustment of settings contrary to the procedure described in the Microscan Systems Inc. owners manual; (4) Upgrading software versions at customer request unless required to meet specifications in effect at the time of purchase; (5) Units returned and found to have no failure will be excluded; (6) Claims for damage in transit are to be directed to the freight carrier upon receipt. Any use of the product is at purchaser's own risk. This limited warranty is the only warranty provided by Microscan Systems Inc. regarding the product. Except for the limited warranty above, the product is provided "as is." To the maximum extent permitted by law, this express warranty excludes all other warranties, express or implied, including but not limited to, implied warranties of merchantability and. Technical support questions may be directed to: helpdesk@microscan.com. Register your product with Microscan: www.microscan.com/register. Microscan Systems Inc. does not warrant that the functions contained in the product will meet any requirements or needs purchaser may have, or that the product will operate error free, or in an uninterrupted fashion, or that any defects or errors in the product will be corrected, or that the product is compatible with any particular machinery.

Limitation of Liability

In no event shall Microscan Systems Inc. be liable to you or any third party for any special, incidental, or consequential damages (including, without limitation, indirect, special, punitive, or exemplary damages for loss of business, loss of profits, business interruption, or loss of business information), whether in contract, tort, or otherwise, even if Microscan Systems Inc. has been advised of the possibility of such damages. Microscan Systems Inc.'s aggregate liability with respect to its obligations under this warranty or otherwise with respect to the product and documentation or otherwise shall not exceed the amount paid by you for the product and documentation. Some jurisdictions do not allow the exclusion or limitation of incidental or consequential damages or limitations on an implied warranty, so the above limitation or exclusion may not apply to you. This warranty gives you specific legal rights, and you may also have other rights which may vary from state to state.

Tel: 425.226.5700 | Fax: 425.226.8250 | helpdesk@microscan.com

Table of Contents

Chapter 1	Quick Start	
	Check Required Hardware	1-2
	USB Interface	1-3
	RS-232 Interface	1-4
	Install ESP	1-5
	Select Model	1-6
	Select Protocol and Connect to Imager	1-7
Chapter 2	Using ESP	
	EZ Mode	2-2
	Application Mode	2-3
	Tree Controls	2-4
	Menu Toolbar	2-5
	Send/Receive	2-14
Chapter 3	Basic Operations	
	Practice Targeting	3-2
	Determine Optimum Position	3-3
Chapter 4	Communications	
	Communications by ESP	4-2
	Communications Overview	4-3
	USB Interface	4-4
	RS-232 Interface	4-5
	Preamble	4-7
	Postamble	4-8
	Preamble and Postamble by ESP	4-9
	Keyboard Mapping	4-10
	Text Commands	4-11
	Other Communications Settings in ESP	4-12
Chapter 5	Symbologies	
	Symbologies by ESP	5-2
	Aztec	5-3
	Codabar	5-4
	Codablock A / Codablock F	5-5
	Code 11	5-6
	Code 39	5-7
	Code 93	5-9
	Code 128	5-10
	Composite	5-11
	Data Matrix	5-12
	Interleaved 2 of 5	5-13
	Maxicode	5-14
	Matrix 2 of 5	5-15
	MicroPDF417	5-16

MSI Plessey.....	5-17
NEC 2 of 5.....	5-18
PDF417.....	5-19
Pharmacode.....	5-20
QR Code.....	5-22
GS1 DataBar.....	5-23
UPC/EAN/JAN.....	5-24
Symbology Identifier.....	5-25
Chapter 6 I/O Parameters	
I/O Parameters by ESP.....	6-2
HS-2D Operational Feedback.....	6-3
Automatic Gain Control (AGC).....	6-4
Image Quality.....	6-5
Chapter 7 Advanced Operations	
Continuous Operations.....	7-2
Lock Settings.....	7-3
Button Stay-Down Time.....	7-4
Mirroring.....	7-5
Motion Detection.....	7-6
Chapter 8 Terminal	
Terminal View.....	8-2
Find.....	8-3
Send.....	8-4
Macros.....	8-5
Terminal Right-Click Menu.....	8-6
Terminal Dropdown Menu.....	8-7
Chapter 9 Utilities	
Device Control.....	9-2
Differences from Default.....	9-3
Firmware.....	9-4
Advanced.....	9-6
Appendices	
Appendix A General Specifications.....	A-2
Appendix B Electrical Specifications.....	A-4
Appendix C HS-2D Maintenance.....	A-7

About the HS-2D Handheld Reader

The HS-2D Handheld Reader, with point-and-click triggering, can read both 1D and 2D symbols and transfer (or buffer and transfer later) decoded data. The HS-2D Handheld Reader is available in USB and RS-232 cabled options.

The HS-2D features a 1.3 million pixel CMOS sensor, and a 400 MHz processor. The imager automatically discriminates between all major 1D and 2D symbologies.

The HS-2D Handheld Reader can be configured by reading Data Matrix symbols encoded with a wide variety of setup commands, or by using Microscan's **ESP**[®] Software.

About This Manual

This manual provides complete information on setting up, installing, and configuring the HS-2D Handheld Reader. The chapters are presented in the order in which the imager would be assembled, configured, and optimized.

Highlighting

Cross-references and web addresses are highlighted in **blue bold**.

References to **ESP**, its toolbar headings (Communications, Symbologies, I/O Parameters, etc.) and menu headings are highlighted in **Bold Initial Caps**.

Statement of Agency Compliance



The HS-2D has been tested for compliance with FCC regulations and was found to be compliant with all applicable FCC Rules and Regulations.

IMPORTANT NOTE: To comply with FCC RF exposure compliance requirements, this device must not be co-located or operate in conjunction with any other antenna or transmitter.

CAUTION: Changes or modifications not expressly approved by the party responsible for compliance could void the user's authority to operate the equipment.



The HS-2D has been tested for compliance to CE (Conformité Européenne) standards and guidelines and was found to conform to applicable CE standards, specifically the EMC requirements EN 55024, ESD EN 61000-4-2, Radiated RF Immunity EN 61000-4-3, ENV 50204, EFT EN 61000-4-4, Conducted RF Immunity EN 61000-4-6, EN 55022, Class B Radiated Emissions, and Class B Conducted Emissions.

Statement of RoHS Compliance

All Microscan readers are RoHS-Compliant. All compliant readers were converted prior to March 1, 2007. All standard accessories in the Microscan Product Pricing Catalog are RoHS-Compliant except 20-500013-01 and 98-000039-02. These products meet all the requirements of the European Parliament and the Council of the European Union for RoHS compliance. In accordance with the latest requirements, our RoHS-compliant products and packaging do not contain intentionally added Deca-BDE, Perfluorooctanes (PFOS) or Perfluorooctanoic Acid (PFOA) compounds above the maximum trace levels. To view the documents stating these requirements, please visit:

<http://eur-lex.europa.eu/LexUriServ/LexUriServ.do?uri=CELEX:32002L0095:EN:HTML>

and

<http://eur-lex.europa.eu/LexUriServ/LexUriServ.do?uri=OJ:L:2006:372:0032:0034:EN:PDF>

Please contact your sales manager for a complete list of Microscan's RoHS-Compliant products.

This declaration is based upon information obtained from sources which Microscan believes to be reliable, and from random sample testing; however, the information is provided without any representation of warranty, expressed or implied, regarding accuracy or correctness. Microscan does not specifically run any analysis on our raw materials or end product to measure for these substances.

The information provided in this certification notice is correct to the best of Microscan's knowledge at the date of publication. This notice is not to be considered a warranty or quality specification. Users are responsible for determining the applicability of any RoHS legislation or regulations based on their individual use of the product.

1 Quick Start

Contents

Check Required Hardware	1-2
USB Interface	1-3
RS-232 Interface	1-4
Install ESP	1-5
Select Model	1-6
Select Protocol and Connect to Reader	1-7

This section is designed to get your HS-2D Handheld Reader up and running quickly so you can get a sense of its capabilities and test sample symbols. Detailed setup information for configuring the reader for your specific application can be obtained in the subsequent sections.

Your interface type will determine how data is received by your host. When sending data by USB, you must open a text editor in your host computer. When sending data serially, you must use a terminal program such as HyperTerminal or **ESP's Terminal** view (RS-232 only).

Check Required Hardware

Parts List for USB HS-2D Handheld Reader:

- One HS-2D Handheld Reader
- One 6 ft. USB cable (pre-attached to reader)

Parts List for RS-232 HS-2D Handheld Reader:

- One HS-2D Handheld Reader
- Cable clip attachment
- Spacer
- Two threaded screws
- 8 ft. coiled R-232 cable
- Power supply

USB Interface

Note: The USB interface draws its power from the host computer.

USB Configuration

Item	Description	Part Number
1	HS-2D Handheld Reader	98-000107-01
2	USB Cable	Included

Installation Steps for USB

1. Connect the USB cable to the HS-2D.
2. Connect the USB cable to the host.
You do not need to power off your host computer.
3. Open any program in your host computer that can receive keyboard text.
4. Read the **Reset to USB Factory Defaults** symbol below:



M049_03

**Reset to USB
Factory Defaults**

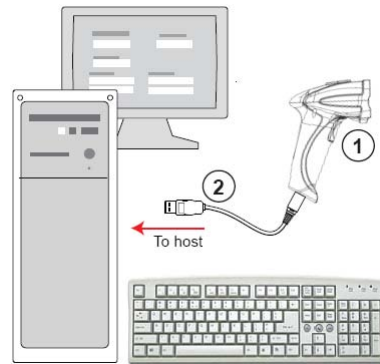

USB Configuration

5. Read the **Save Settings** symbol.



M188_02

**Save
Settings**



Test Symbol
(ABCDEFGHIJKLMNOP)

RS-232 Interface

Note: Unlike USB, the RS-232 interface does not draw its power from the host computer.

RS-232 Configuration

Item	Description	Part Number
1	HS-2D Handheld Reader	98-000107-01
3	RS-232 Interface Kit (USA)	98-000074-04
	RS-232 Interface Kit (Europe)	98-000074-05
	RS-232 Interface Kit (UK)	98-000074-06

Installation Steps for RS-232

1. Power-off the host computer.
2. Connect the 8-pin mini-DIN on the cable to the HS-2D.
3. Connect the 9-pin D-sub connector to the host computer's serial port.
4. Connect the cable to the power supply.
5. Plug in the power supply and power-on the host computer.
6. Start up a terminal program (such as **ESP's Terminal** view or HyperTerminal) and set to **57.6K** baud, **8** data bits, **none** parity, and **2** stop bits.
7. Read the **Reset to RS-232 Factory Defaults** symbol below.

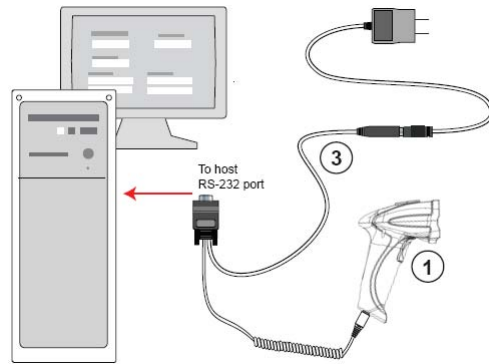

RS-232 Configuration

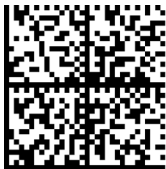

M418_02

**Reset to RS-232
Factory Defaults**

8. Read the **Save Settings** symbol.



M188_02

**Save
Settings**



Test Symbol
(ABCDEFGHIJKLMNOP)

Install ESP

ESP Software can be found on the Microscan Tools CD that is packaged with the HS-2D.

1. Follow the prompts to install ESP from the CD.
2. Click on the ESP icon to run the program.



Note: ESP can also be installed from the **Download Center** at www.microscan.com.

ESP System Requirements

- 166 MHz Pentium processor (Pentium II processor recommended)
- Windows Vista, XP, or 2000 operating system
- Internet Explorer 5.0 or higher
- 64 MB minimum RAM (128+ MB RAM recommended)
- 80 MB hard drive space
- 800 x 600 minimum 256 color display (1024 x 768 32-bit color recommended)

Important: The reader must be in one of the modes below to communicate with **ESP**.

USB	USB Connect Mode	
RS-232	RS-232 Connect Mode	



Select Model

When you start **ESP**, the following menu will appear:



If you need to select another model later, click **Switch Model** at the top of the screen.



1. Click the HS-2D button and then click **OK**. If you do not want to make this selection every time you start **ESP**, uncheck “Show this dialog at startup”.
2. Select the default reader name (**HS-2D-1**), or type a name of your choice in the **Description** text field and click **OK**.
3. Click **Yes** when this dialog appears:

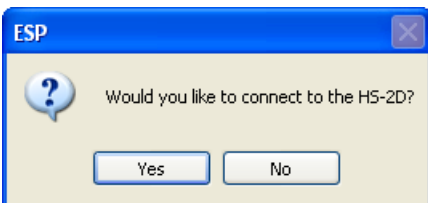

Select Protocol and Connect to Reader

RS-232

- In the **Select Protocol** dialog box, select the communications protocol you are using and click **Next**.

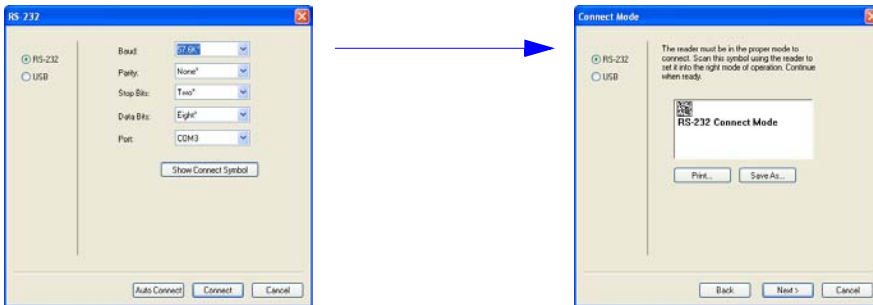

- Print the **RS-232 Connect Mode** symbol (also shown in the **Install ESP** step) and decode it with the reader to ensure that you are in the correct communications mode. Keep the printed symbol in a convenient place for future use.
- Click **Next** when you are finished.
- The **Com Port** dialog will then reappear. Select which communications port you are using. If you don't see your communications port listed on the dropdown menu, select **Other**.



- Click **Connect**.
- When you are connected successfully, the **CONNECTED** message will appear in a green box in the status bar at the bottom right of the screen.

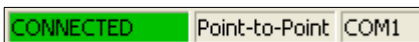

If the connection attempt fails, enable a different communications port, check your port connections, and try again.

You are now ready to configure your reader using **ESP**. Subsequent sections provide more detailed information about **ESP's** configuration options.

Select Protocol and Connect to Reader

USB

- In the **Select Protocol** dialog box, select the communications protocol you are using and click **Next**.

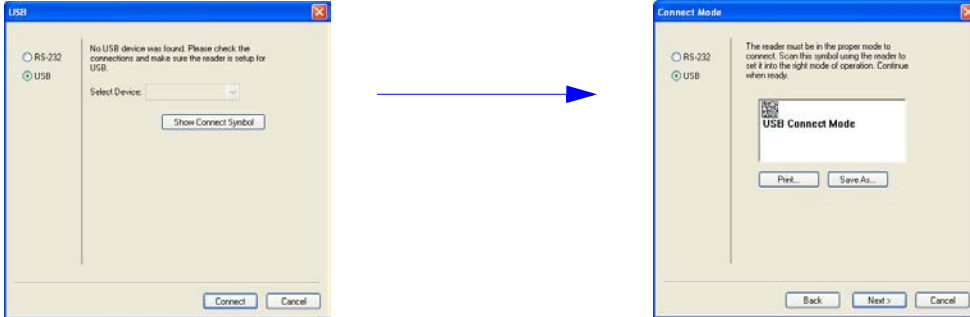

- Print the **USB Connect Mode** symbol (also shown in the **Install ESP** step) and decode it with the reader to ensure that you are in the correct communications mode. Keep the printed symbol in a convenient place for future use.
- Click **Next** when you are finished.

The **Select Device** dialog will then reappear:

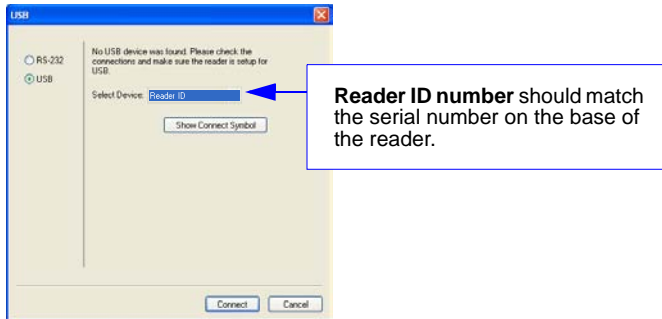

- You will see a “Reader” ID number in the **Select Device** field. Click **Connect**.
- When you are connected successfully, the **CONNECTED** message will appear in a green box in the status bar at the bottom right of the screen.

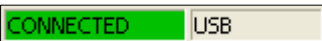

You are now ready to configure your reader using **ESP**. Subsequent sections provide more detailed information about **ESP**'s configuration options.

2 Using ESP

EZ Mode	2-2
Application Mode	2-3
Tree Controls	2-4
Menu Toolbar	2-5
Send/Receive	2-14

This section is designed to help you understand the structure and application of **ESP**.

When you open **ESP**, unless otherwise specified in the **ESP Preferences** dialog accessible from the **Options** heading on the menu toolbar, you will enter **EZ Mode** for initial setup.

From there, you can enter **Application Mode (App Mode)** and access several configuration menus (**Communications**, **Read Cycle**, **Symbologies**, **I/O Parameters**, a **Terminal** interface, and a **Utilities** interface).

ESP can be used to configure the HS-2D Handheld Reader in the following ways:

- **Tree Controls:** Each configuration menu contains a list of all option settings that pertain to that specific element of reader operation. For example, the **Communications** menu shows a **Communications Mode** command, and then the options **RS-232 Serial**, **USB Keyboard**, and **USB Native (HID)**, all of which are accessible from a dropdown menu.
- **Graphic User Interfaces:** Settings can be configured using such point-and-click tools as radio buttons, tabs, spin boxes, check boxes, and drag-and-drop functions.
- **Terminal:** **ESP**'s **Terminal** interface allows you to send configuration and utility commands directly to the reader by typing them in the provided text field.

EZ Mode

The **EZ Mode** screen is the first thing you will see when you start **ESP**. **EZ Mode** will help you get your reader up and running quickly, and will acquaint you with the **ESP** interface.

The screenshot shows the ESP - Untitled application window. The menu bar includes File, Model, Options, Connect, and Help. The toolbar contains three icons: App Mode, Autoconnect, and Switch Model. A callout box points to the toolbar with the text: "The **EZ Mode** toolbar allows you to switch to **App Mode**, check your connection parameters, and to switch models."

The main interface is divided into two columns. The left column contains a "Welcome to Easy Setup Program" section with instructions for decoding symbol data and taking pictures. The right column contains a "Decode Symbol Data" section with a "Decode" button and a "Symbol Data" field, and a "Taking Pictures" section with a "Start" button. A callout box points to the "Decode" button with the text: "The **Decode** button allows you to begin capturing images and displaying decoded symbol data right away."

Below the "Taking Pictures" section is a "Save Image..." button. A callout box points to the "Start" button with the text: "The **Taking Pictures** button menu allows you to capture images that can be displayed in the view below."

At the bottom of the interface, there is a "Save Image..." button. A callout box points to the image area with the text: "When an image is captured, it is displayed here. Double click this image to view it in a larger format. Click **Save Image** to save it to a location of your choice."

At the bottom left of the window, it says "For Help, press F1."

Application Mode

Application Mode gives you access to a robust configuration environment, including tree controls that let you make precise changes to operation parameters, and graphic interfaces that make configuring your reader easy and intuitive.

The screenshot shows the Application Mode software interface. The top menu bar includes File, Model, Options, Connect, View, and Help. Below the menu bar is an operations bar with icons for EZ Mode, Connect, Send/Recv, Switch Model, Parameters, Terminal, and Utilities. Below the operations bar is a configuration bar with tabs for Communication, Read Cycle, Symbolologies, and I/O. The main window is divided into two panes: Parameters and ESP Values. The Parameters pane shows a tree view of configuration options, including Communications Mode, RS232, and Keyboard Mapping. The ESP Values pane shows fields for Preamble and Postamble characters, and a grid of buttons for assigning characters to specific keys.

Callout boxes provide the following instructions:

- Click here to return to **EZ Mode**.
- Click on this icon to return to this view from **Utilities** or **Terminal**.
- Menu toolbar
- Click these buttons to Send and Receive commands or switch reader models.
- Click here to open **Terminal**.
- Click here for **Batch Files** and **Firmware**.
- Click these tabs to access configuration tree controls.
- Assign Preamble and Postamble characters using the simple interface shown above.

Note: For specific information on any of the icons shown above in the operations bar or configuration bar, see corresponding sections.

Tree Controls

To make changes to configuration settings in the tree control menus:

The screenshot shows a configuration window with two main sections: 'Parameters' and 'ESP Values'. Under 'Parameters', there is a tree view with 'Communications' expanded to show 'RS232'. The 'Batch Mode' dropdown menu is open, displaying 'Detect RS232*' as the selected option. Other options include 'Assume Always Connected', 'Two', 'Eight', and 'US English (with leading 0 in alt-num)'. Five callout boxes provide the following instructions:

1. **Left click** on the +/- to expand or collapse the tree.
2. **Double click** on the parameter and click once in the selection box to view options.
3. Place your cursor in the selection box, scroll down to the setting you want to change and **click once** on the setting.
4. **Left click** again on the open screen to complete the selection.
5. **Right click** on the open screen and select **Save to Reader** to implement the command in the reader.

The reader must be in one of the modes below to communicate with **ESP**.

USB	<p>USB Connect Mode</p> 
RS-232	<p>RS-232 Connect Mode</p> 

Menu Toolbar

File > New

Whenever **New** is selected from the **File** menu, the default configuration of **ESP** is loaded.

Open / Save

When **Save** or **Save As** is selected, the **ESP** configuration is saved to the host computer's hard drive and available whenever the same file is selected under **Open**.

When you save menu changes to your hard drive, these changes are not saved to your reader. The diagram below shows how settings can be saved and received between **ESP** and the reader, and **ESP** and the host hard drive.

File	
New	Ctrl+N
Open...	Ctrl+O
Save	Ctrl+S
Save As...	
<hr/>	
Print...	Ctrl+P
<hr/>	
Import...	
Export...	

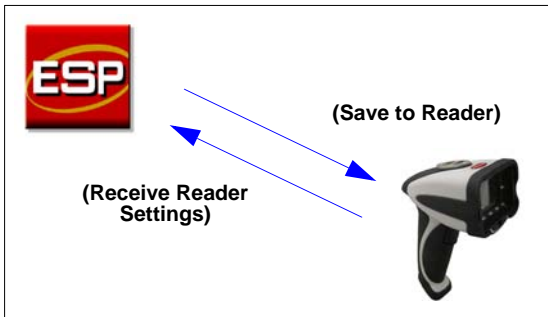

Import / Export

Import converts the ASCII settings from a text file to **ESP** configuration settings.

Export converts the active **ESP** configuration settings to an ASCII text file.

Model

The **Model** menu allows you to select between reader models. When you choose another model, the current connection with your present model will be terminated.

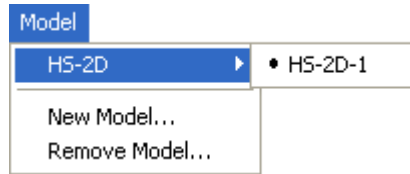

New Model

To connect to another model, select **New Model**, choose the model you want, and click **OK**. All models you have selected and enabled will continue to appear in the dropdown model menu. The **New Model** option is repeated when you click the **Switch Model** button on the top row of icons.



Options

You can use the **Options** menu to save memos and set up **ESP** preferences.

Preferences will be saved and loaded into **ESP** the next time **ESP** is opened, whether or not you save the **ESP** file to the host computer.

Preferences > General Tab

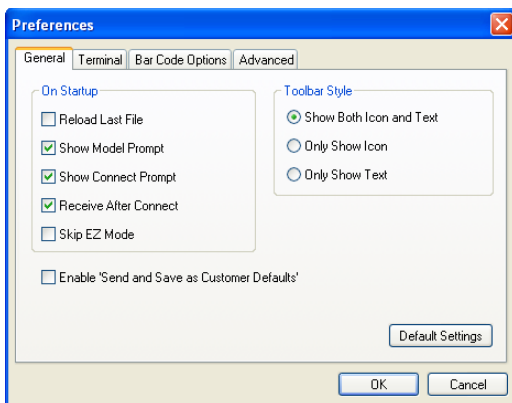

Reload Last File

At startup, reloads the last file saved to the computer.

Show Model Prompt

At startup, remembers the last connected model and displays it in the **Connecting...** dialog whenever you attempt to connect.

Skip EZ Mode

At startup, skips **EZ Mode** and opens directly in **App Mode**.

Show Connect Prompt

At startup, displays the **Would you like to connect...** prompt.

Receive After Connect

At startup, loads the reader's settings into **ESP**. (This is not recommended if you want to preserve your **ESP** settings for future use.)

Show Both Icon and Text (Default)

Sets the toolbar to display icons and names of all operations.

Only Show Icon

Sets the toolbar to display only icons representing operations, without text.

Only Show Text

Sets the toolbar to display names of operations only, without icons.

Terminal Tab

When **Show Non-Printable Characters** is checked, characters such as 'CRLF' will be displayed in the terminal window. When the **Enhanced Format** radio button is checked, subscript and superscript formatting is shown.

When **Display incoming data even when not in focus** is checked, data from the reader will continue to appear in the terminal even when **ESP** is not the top window on the host computer's screen.

When **Enable Echo** is checked, the terminal window displays user-entered data.

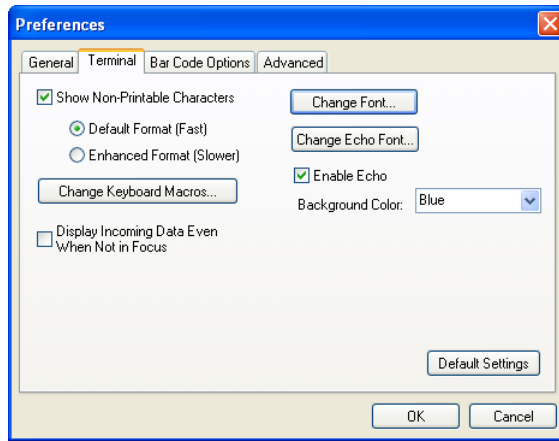

Change Keyboard Macros

Clicking the **Change Keyboard Macros** button brings up the **Function Keys** dialog. In this dialog you can select the desired function key and then enter your macro keystrokes in the associated key map. For example, to make **Ctrl-F2** the keystroke to send a trigger character, select **F2**, then in the **Ctrl** row, enter **<trigger character>** and click **OK**. Then whenever the **Ctrl-F2** keystroke is pressed, the trigger character will start the read cycle.

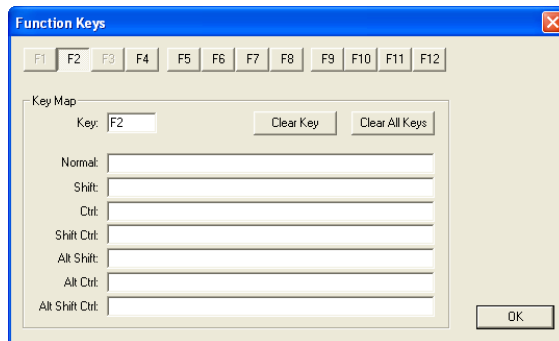

Note: The **F1** key is reserved for opening **ESP** Help and the **F3** key is reserved for the **Find Next** function.

Change Font

Sets the font characteristics for data received from the reader.

Change Echo Font

Sets the font characteristics of user-entered data.

Bar Code Options Tab

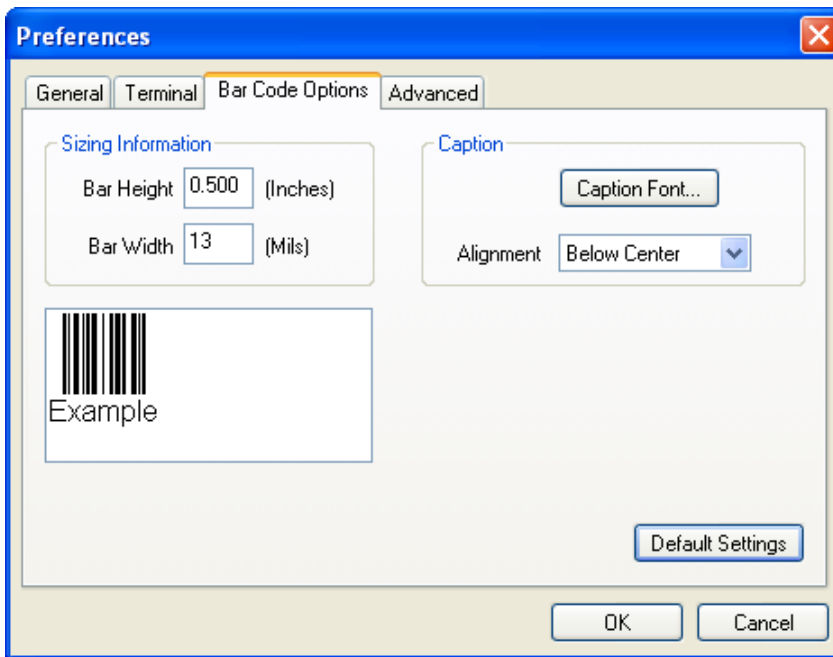

Sizing Information

Sets element size (in thousands of an inch) of symbols that you create and print from the **Bar Code Dialog** under **View**.

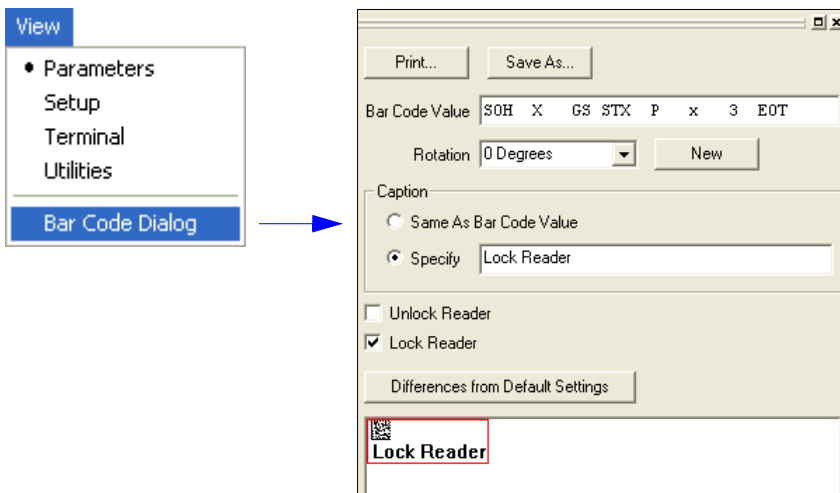

Advanced Tab

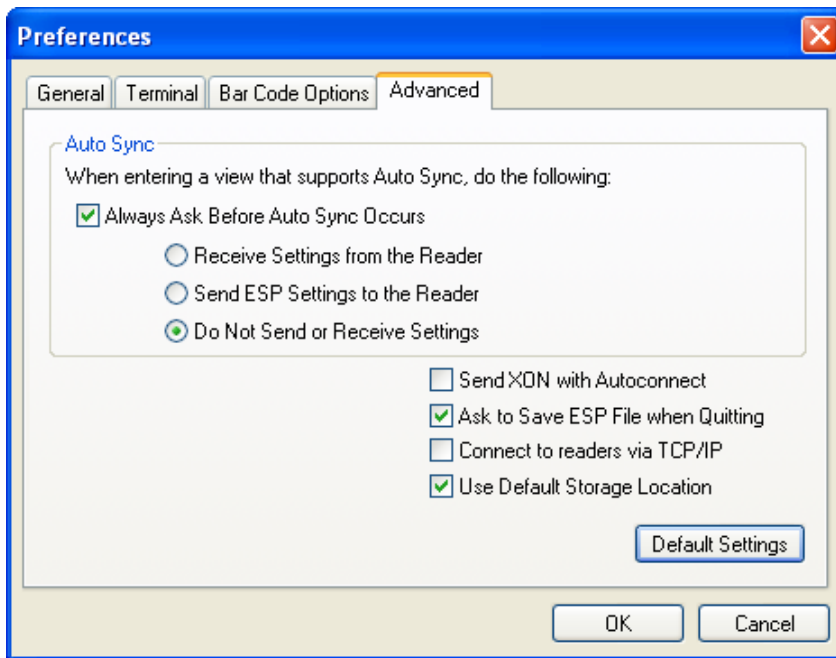

The Auto Sync dialog on the **Advanced** tab allows you to determine whether Auto Sync will be automatically enabled in sections of **ESP** where it is used, or if it will ask you before it enables Auto Sync functions.

Always Ask Before Auto Sync Occurs

If you check this option box, you are then able to determine what specific Auto Sync functions will be enabled. **Receive Settings from the Reader** will automatically send the reader's settings to **ESP** when Auto Sync is enabled. **Send ESP Settings to the Reader** will automatically send all reader configuration settings chosen in **ESP** to the reader. **Do Not Send or Receive Settings** creates a condition in which Auto Sync will not send reader settings to **ESP**, or send **ESP** settings to the reader.

Send XON with Auto-Connect

Sends an **XON (Begin Transmission)** command to the reader before starting the **Auto-Connect** routine.

Document Memo

The information you type in the **Document Memo** field will appear in a context-sensitive text box whenever your cursor hovers over the **Document Memo** item on the **Options** menu.

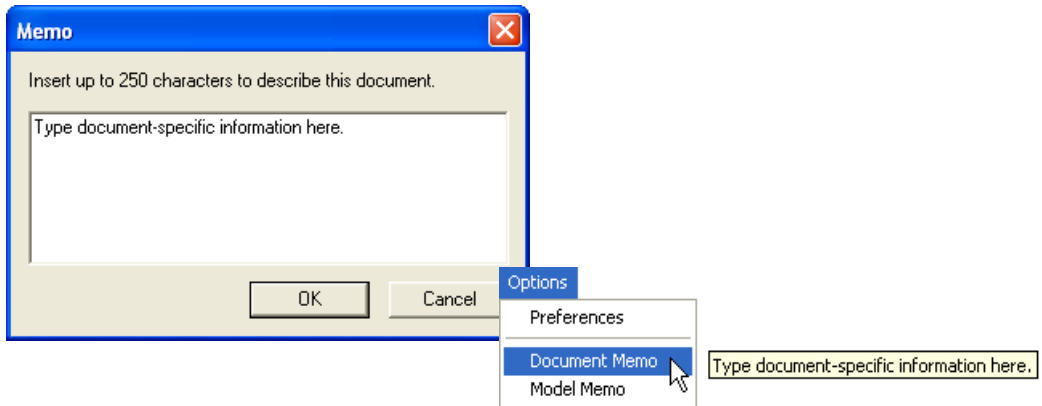

Model Memo

Similar to **Document Memo**, the information you type in the **Model Memo** field will appear in a context-sensitive text box whenever your cursor hovers over the **Model Memo** item on the **Options** menu. Memos created in **Model Memo** are specific to the model enabled when the message was created.

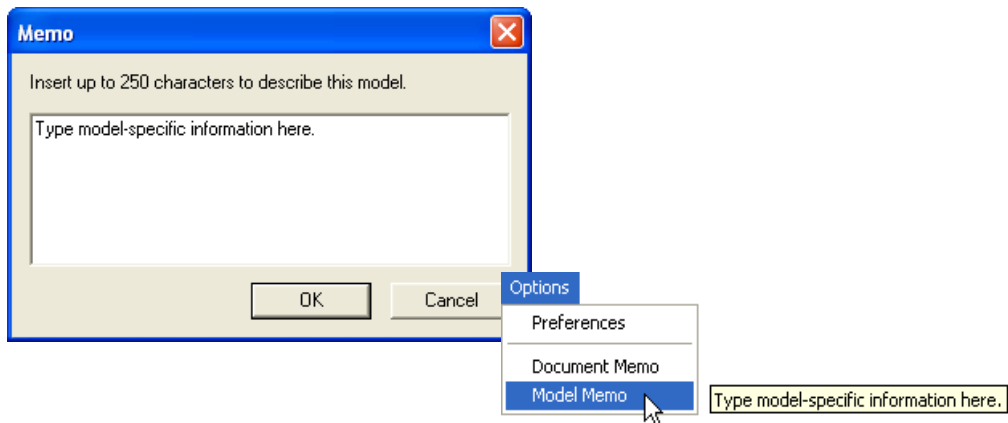

Note: Memos must be saved in a **.esp** file if you want them to be available in your next session. If you do not save your current session, any memos that you have entered during the session will be discarded, and will be unavailable in your next session.

Connection Wizard

When you choose to connect to the reader via the **Connection Wizard**, you will first need to select the correct protocol (see [Select Protocol and Connect to Reader](#)).

When you have successfully connected to the reader you will see one of the two following displays in the status bar at the lower right of the screen:

RS-232:

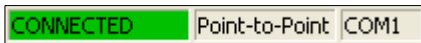

USB:



View

The options in the **View** menu correspond to icons on the operations toolbar (**Parameters**, **Setup**, **Terminal**, **Utilities**). Each option allows you to configure the reader or to perform various other functions in the chosen view.

The **View** menu also allows you to access the **Barcode Dialog**.



Bar Code Dialog

In the **Bar Code Dialog** you can directly type the text and commands you want to encode. This allows you to create configuration symbols that you can print and read with the reader.

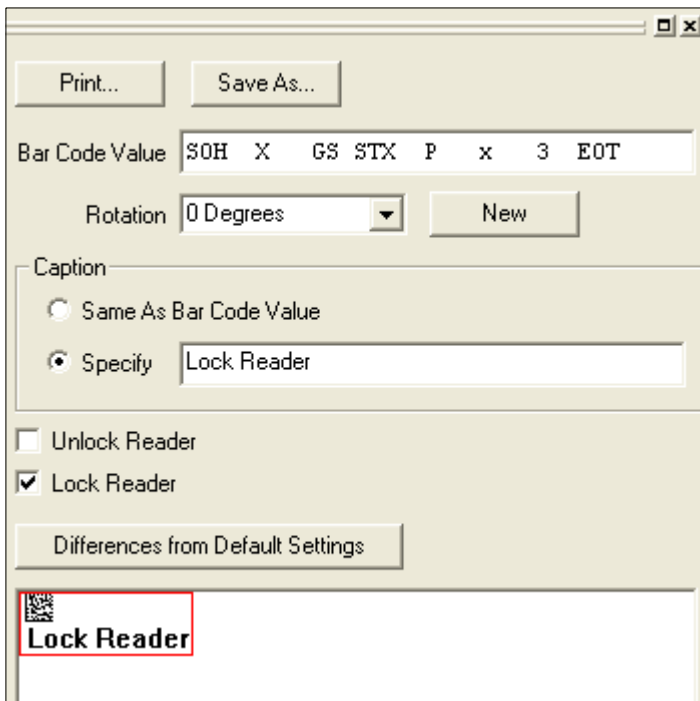

Send/Receive

To access **Receive**, **Save**, **Default**, and **Advanced** options, click the **Send/Recv** button.



You can also access these options by right-clicking in any of the configuration views.

Receive Reader Settings

From the **Send/Recv** menu, select **Receive Reader Settings**.

This option is useful if you want to receive the reader's settings and save them as a file for later retrieval. For example, if your reader has settings that you do not want to change, choosing **Receive Reader Settings** will allow you to load those settings to **ESP** and save them as an **ESP** file.

Receiving the reader's settings also assures that you will not subsequently save any unwanted configuration changes previously made in **ESP**.

Select this option if you want to upload the reader's settings to **ESP**. For example, if your **ESP** file has a number of custom settings that you want to maintain and download to the reader, you will lose those **ESP** settings if you choose to receive settings from the reader.

Save to Reader

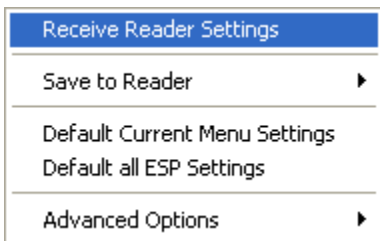

Send, No Save

This saves **ESP** settings to current memory.

Send and Save

This activates all changes in current memory *and* saves to the reader.

Default

When you select **Default Current Menu Settings** or **Default all ESP Settings** you are *only* defaulting settings in **ESP**. The reader is not affected unless you download new settings.

Advanced Options

Send Current View

This is the same as **Save to Reader > Send No Save** except that only the commands in the current menu tree are sent.

Send Current Command

This is the same as **Send Current View** above, but only saves the command that is currently selected.

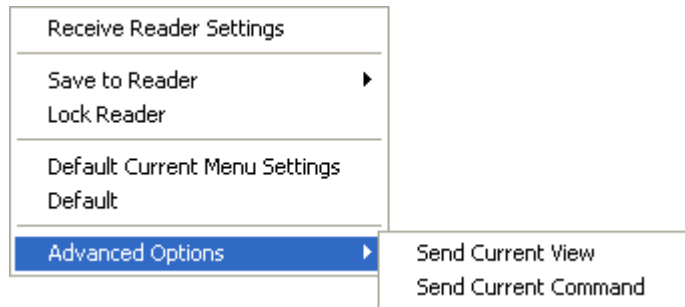

Send/Receive

3 Basic Operations

Contents

Practice Targeting	3-2
Determine Optimum Position.....	3-3

This section explains how to practice targeting and triggering, and how to begin configuring the reader.

Practice Targeting

When first connecting, allow approximately 3 seconds for the reader to initialize.

1. Hold the reader steady and point at a symbol about **2.3 inches (5.8 cm)** away.
2. Squeeze and hold the trigger. Red and green targeting spots will appear in front of the reader.
3. Center the red and green spots on the symbol and wait a second or two for a decode.

For configuration symbols, you will hear **2 beeps** when a good read occurs. For data symbols, you will hear **1 beep** when a good read occurs.

4. If no decode occurs, slowly draw away from the symbol while holding the laser spot steadily in place.

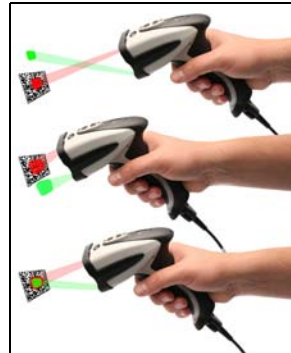

Test Symbol



ABCDEFGHIJKLMN

Targeting Suggestions

- Typically, you should not hold the reader exactly perpendicular to the symbol. Position the reader about 15 to 30 degrees to avoid specular reflection.
- Do not wave the reader side-to-side or up-and-down, or attempt to sweep across a symbol; sudden movements will create fuzzy images and result in failed read attempts.
- The reader is omnidirectional and can read a symbol from any position (The exception to this is with certain linear symbols; in these cases, the read area will be oriented to the length of the symbol.)

Targeting LEDs

Read the configuration symbols below to enable or disable red and green targeting LEDs.



M732_01
**Red Targeting
LED On**



M733_01
**Red Targeting
LED Off**



M734_01
**Green Targeting
LED On**



M735_01
**Green Targeting
LED Off**

Determine Optimum Position

1. Position the reader in front of the symbol.
 - **2.3 inches (5.8 cm).**
2. Determine the optimum read position by triggering at different distances and angles. Smaller symbols require the unit to be held close to the optimal focal distance. For larger symbols, which have a larger depth of field, refer to the chart below.

Test Symbol



ABCDEFGHIJKLMNPO

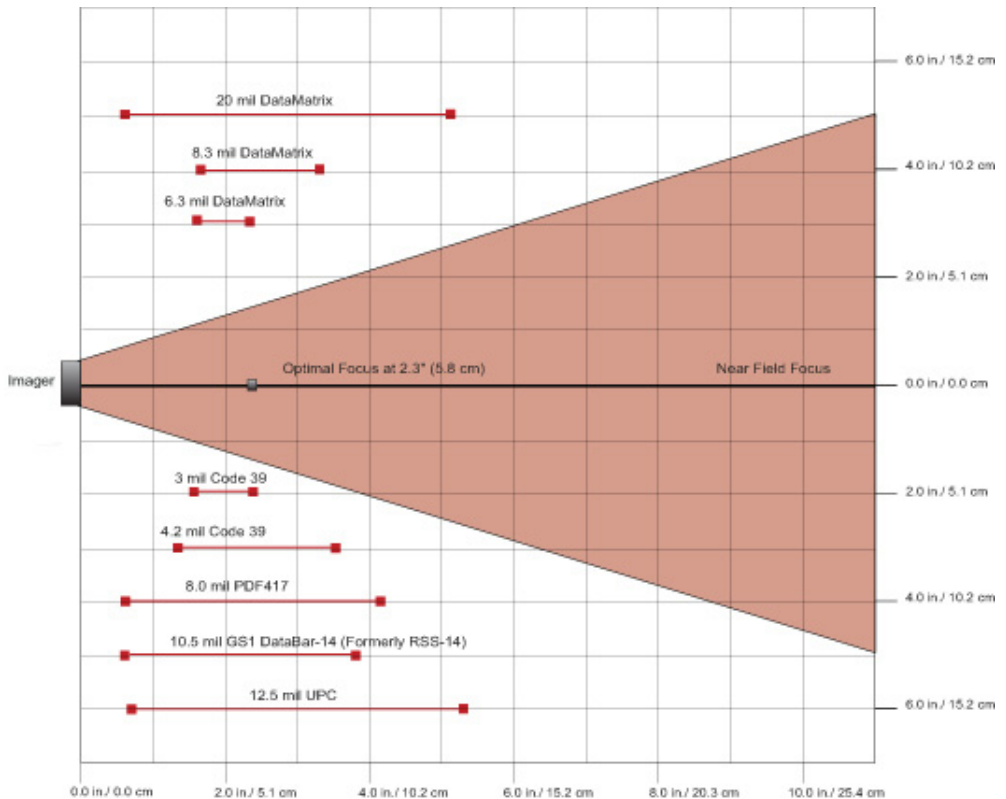

4 Communications

Contents

Communications by ESP	4-2
Communications Overview	4-3
USB Interface	4-4
RS-232 Interface	4-5
Preamble	4-7
Postamble.....	4-8
Preamble and Postamble by ESP	4-9
Keyboard Mapping	4-10
Text Commands	4-11
Other Communications Settings in ESP.....	4-12

This section includes connection parameters and options for communicating with the HS-2D Handheld Reader in various interfaces.

Communications by ESP

To make changes to configuration settings in the **Communications** tree control:

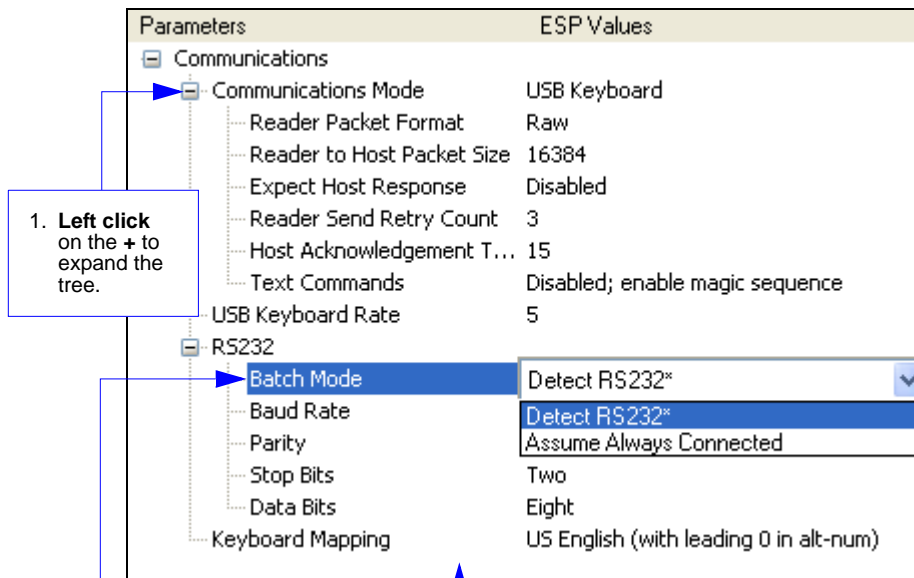

1. **Left click** on the + to expand the tree.

2. **Double click** on the parameter and click once in the selection box to view options.

3. Place your cursor in the selection box, scroll down to the setting you want to change and **click once** on the setting.

4. **Left click** again on the open screen to complete the selection.

5. **Right click** on the open screen and select **Save to Reader** to implement the command in the imager.

Communications Overview

All HS-2D Handheld Readers are shipped with a USB cable. You can also add RS-232 capabilities and configure your imager accordingly. Whenever you default the imager, it will return to the default settings of whichever interface you are using. Defaulting the imager does not remove preamble and postamble formatting.

Note: You must use **USB Connect Mode** or **RS-232 Connect Mode** to connect to **ESP**. Once the imager is connected to **ESP**, you can select your communications mode and set other communication parameters.

USB

With USB communications, the imager connects directly to the host's USB port from which it draws its power. Data is displayed by any open Windows-based program that can capture text in USB Keyboard Mode.

RS-232

With RS-232 communications the imager communicates with the host through a communications program such as HyperTerminal.

Default settings for establishing RS-232 communications are:

Baud =	57.6K
Stop Bits =	2
Data Bits =	8
Parity =	None

USB Interface

USB Keyboard is the default interface in which data is transferred to a Windows-based text program as keyboard data.

See [USB Interface](#) for detailed steps on setting up the USB Interface.

USB Keyboard Mode

Data is entered as keyboard sequences. You need to read this symbol whenever you are changing from a different interface to USB.



M134_02

USB Downloader Mode

This mode is the standard way of transferring unformatted, unpackitized data to the imager through the USB port.



M133_01

USB Native Two-Way Mode

This mode is used when the user needs error-corrected communication between the HS-2D and the host the USB port.



M135_04

USB Virtual COM Mode

This mode allows an HS-2D in a USB configuration to function as a virtual serial COM port. This mode requires installation of a USB Virtual COM driver. Contact your Microscan sales representative to request this driver, as well as installation instructions.



M668_01

USB HID POS (Terminal ID 131)

This mode allows a USB-cabled HS-2D to communicate as a USB HID POS (Terminal ID 131) device.



M736_01

RS-232 Interface

Enabling either of these modes will disable USB communications and require you to default the imager or read the “USB Keyboard” symbol to return to USB.

See [RS-232 Interface](#) for detailed steps on setting up the RS-232 Interface.

RS-232 Default Settings

This mode is the standard way of transferring unformatted, unpacketized data through the RS-232 port.



M418_02

You will need to read this symbol whenever you set up RS-232 communications.

Baud Rate (RS-232)

Baud Rate is the rate at which the imager and host transfer data. It only needs to be changed if necessary to match the host setting.



1200

M092_01



19.2K

M096_01



2400

M093_01



38.4K

M097_01



4800

M094_01



57.6K (Default)

M098_01



9600

M095_01



115.2K

M099_01



Save Settings

M188_02

Parity (RS-232)

Parity is an error detection routine in which one data bit in each character is set to **1** or **0** so that the total number of 1 bits in the data field is even or odd. It only needs to be changed if necessary to match the host setting.



M103_01

None (Default)



M104_01

Odd



M102_01

Even

Stop Bits (RS-232)

Stop Bits are added to indicate the end of each character. This setting should only be changed if necessary to match the host setting.



M106_01

2 Stop Bits (Default)



M105_01

1 Stop Bit

Data Bits (RS-232)

Data Bits are the total number of bits in each character. This setting only needs to be changed if necessary to match the host setting.



M101_01

8 Data Bits (Default)



M100_01

7 Data Bits

Preamble

A **preamble** is a character or series of characters that is added to the beginning of a decoded data string. Preamble characters will appear in the order that they are enabled (left to right). For example, if you enable a comma and then a space, and then decode a symbol containing the data 'ABC', your output will look like this:

, ABC

The only limit to the number of preambles enabled is the total memory size available.

Important: Be sure to save all settings before reading any of the following preamble symbols—otherwise your settings may be lost.



M188_02

Save Settings

Set the desired preamble by reading the appropriate symbol below.



M159_02

Comma



M164_02

Space



M166_01

Tab (USB Only)



M218_02

Tab



M404_01

**Erase All
Preamble Data**



M214_02

**Carriage Return
Line Feed**

Important: Use only with serial applications.

Note: To erase all preamble *and* postamble data, read the following symbol:



M406_02

Erase Preamble and Postamble Data

Postamble

A **postamble** is a character or series of characters that is added to the end of a decoded data string. Postamble characters will appear in the order that they are enabled (left to right). For example, if you enable a space and then a comma, and then decode a symbol containing the data 'ABC', your output will look like this:

ABC ,

The only limit to the number of postambles enabled is the total memory size available.

Important: Be sure to save all settings before reading any of the following postamble symbols—otherwise your settings may be lost.



Save Settings

Set the desired postamble by reading the appropriate symbol below.



Important: Use only with serial applications.

M168_04

Carriage Return



M160_04

Comma



M169_04

Line Feed

Important: Use only with serial applications.



M170_04

**Carriage Return
Line Feed**

Important: Use only with serial applications.



M165_04

Space



M161_04

Enter

Important: Use only with USB or PS/2 Keyboard modes.



M167_04

Tab

Important: Use only with USB or PS/2 Keyboard modes.



M219_04

Tab (RS-232 Only)



M405_02

Erase / None

Important: Reading this symbol will erase all postamble data.

Note: To erase all postamble and preamble data, read the symbol at right:



M406_02

**Erase Preamble
and Postamble
Data**

Preamble and Postamble by ESP

Characters can also be added to the beginning and end of data strings using **ESP**. There are a few different ways to do this, using the interface shown below.

You will see the Communications tree control on the left, and the Preamble/Postamble interface on the right.

When you type ASCII characters directly into the **Preamble** or **Postamble** text fields and then click **Send to Reader**, those preamble or postamble characters are enabled and will appear in data output.

Save pre- and postamble settings and send them to the reader.

Save As...

Send to Reader

Preamble Postamble

/n - Enter key

Insert

Alt Ctrl Shift Windows

Home End Enter Escape

Page Up Backspace

Page Down Up

Left Down Right

Carriage Return (CR) % - Percent Sign Esc 500 ms Delay

Tab - Keystroke/USB Tab - Ascii / - Forward Slash Esc

In addition to typing directly in the text fields and selecting from the dropdown menu, you can also click any of these preset buttons to set a preamble or postamble.

Scroll through a list of all preamble and postamble options, and then click **Insert**.

Keyboard Mapping

The **Keyboard Mapping** feature provides alternatives for keyboards that do not conform to US English mapping.

Note: Universal Keyboard mapping is slightly slower than the other language-specific options, because it maps data by reference to the full set of ASCII characters. The advantage of Universal Keyboard mapping is that it allows any language and keyboard layout to be mapped.

Important: Keyboard Mapping is not to be confused with USB Keyboard Mode, which has an entirely different function—namely to enable USB cabled communications. (See [USB Interface](#)).



M172_01

US English, No Leading 0 for non-printable characters (Default)



M602_01

US English, Leading 0 for non-printable characters



M606_01

US English, Ctrl + char. for non-printable characters



M603_01

French



M604_01

German



M605_01

Japanese



M173_01

Universal Keyboard



M171_01

Custom Keyboard



M585_02

Enable Alternate OS (Windows CE/MAC/Unix/Linux)



M584_02

Disable Alternate OS

Keyboard Mapping by ESP

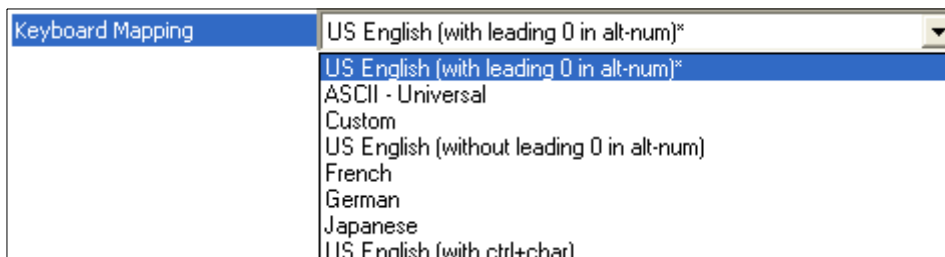

Text Commands

When the **Text Commands** feature is enabled, the HS-2D can accept text commands via RS-232 connections and USB Virtual COM modes.

Note: **Text Commands** are not supported in USB HID Mode.



Enable Text Commands
(Default)



Disable Text Commands

Text Commands by ESP

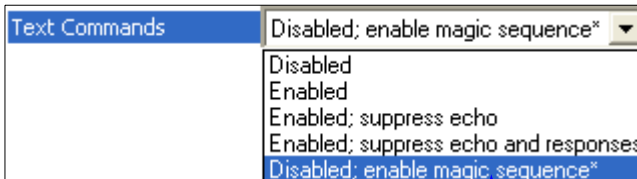

When **Magic Sequence** is enabled, it allows the user to enable **Text Commands** by entering a predetermined series of keystrokes.

When **Text Commands** are set to **Enabled; Suppress Echo**, text that a user enters in the terminal will not be shown. When **Text Commands** are set to **Enabled; Suppress Echo and Responses**, neither user-entered data or reader responses will be shown, and only decoded symbol data will appear in the terminal.
See [Terminal Right-Click Menu](#) for a way to change Echo settings directly in the terminal view.

Entering Magic Sequence

The magic sequence is ;>PA followed by a numeric value of **1**, **3**, or **7**.

- 1** = Enable Text Commands
- 3** = Enabled; Suppress Echo
- 7** = Enabled; Suppress Echo and Responses

In the example below, the magic sequence entered will Enable Text Commands and Suppress Echo and Responses.



Enter the magic sequence in this text field and click **Send**.

Once the magic sequence has been sent, you can send text commands from the same text field.

Other Communications Settings in ESP

Some **ESP** Communications options are unique to the software, and do not have corresponding programming symbols. These options are explained below.

Reader Packet Format

Reader Packet Format	Raw*
	Raw*
	Packet

Data that is sent from the imager to the host in **Raw** format is sent without packet framing or check characters. **One-Way** communication is in a raw format, no response is expected from the host, and data is not resent.

Packetized data is sent with framing (a preamble communicating the amount of data to be transmitted, and a postamble containing error detection) and check characters, and a response is expected from the host. **Two-Way** communication is in packet format.

Reader to Host Packet Size

Reader to Host Packet Size	16384	(1 - 16384)
----------------------------	-------	-------------

The **Reader to Host Packet Size** is the amount of data (in bytes) that is sent to the host in packet format. This feature allows you to set the maximum allowable packet size.

Expect Host Response

Expect Host Response	Disabled*
	Disabled*
	Enabled

When **Expect Host Response** is enabled, the imager will re-transmit data if it doesn't receive acknowledgement from the host.

Reader Send Retry Count

Reader Send Retry Count	3	(1 - 2147483647)
-------------------------	---	------------------

Reader Send Retry Count sets the number of times the imager will re-transmit data before abandoning further send attempts. The minimum retry count is **1**, which represents the initial transmission.

Host Acknowledgement Timeout

Host Acknowledgement Timeout	0.015	Seconds
------------------------------	-------	---------

The **Host Acknowledgement Timeout** is the amount of time (in seconds) that the imager will wait for an acknowledgement from the host before re-sending data.

USB Keyboard Rate

USB Keyboard Rate 1 - 255 (x 1ms)

Requests that the host polls the USB HS-2D at the rate specified (1 to **255** ms).



5 Symbologies

Contents

Symbologies by ESP	5-2
Aztec.....	5-3
Codabar.....	5-4
Codablock A / Codablock F	5-5
Code 11	5-6
Code 39.....	5-7
Code 93.....	5-9
Code 128.....	5-10
Composite	5-11
Data Matrix	5-12
Interleaved 2 of 5.....	5-13
Maxicode	5-14
Matrix 2 of 5.....	5-15
MicroPDF417.....	5-16
MSI Plessey.....	5-17
NEC 2 of 5.....	5-18
PDF417	5-19
Pharmacode	5-20
QR Code.....	5-22
GS1 DataBar	5-23
UPC/EAN/JAN.....	5-24
Symbology Identifier.....	5-25

This section describes the various symbol types that can be read and decoded by the reader. See <http://www.aimglobal.org/standards/aimpubs.asp> for additional information.

Symbologies by ESP

To make changes to configuration settings in the **Symbologies** tree control:

Parameters	ESP Values
[-] Symbologies	
[-] 2D Symbologies	
[-] Data Matrix	Standard
Data Matrix Improvements	Disabled
Data Matrix Locate Effort	Maximum
Data Matrix Rectangular	Disabled
Data Matrix ECC 0 - 140	Disabled
QR Code	Disabled
Aztec Code	Disabled
Maxicode	Disabled
[+] 1D Symbologies	
[-] Stacked Symbologies	
Codablock A	Disabled
Codablock F	Disabled
[-] PDF417	Enabled
Handle PDF417 Invalid Shift	Disabled
Micro PDF417	Disabled
Macro PDF417	Disabled
[+] Composite	Disabled
Symbology Identifier	Disabled
Image Transform	Standard*

1. Left click on the + to expand the tree.

2. Double click on the parameter and click once in the selection box to view options.

3. Place your cursor in the selection box, scroll down to the setting you want to change and click once on the setting.

4. Left click again on the open screen to complete the selection.

5. Right click on the open screen and select **Save to Reader** to implement the command in the reader.

Aztec

Read the following symbols to enable/disable **Aztec** settings:

Aztec On



M273_01

Aztec Off (Default)



M272_01

Aztec by ESP

Aztec	Disabled*
	Disabled*
	Standard
	Inverse
	Both

Sample Aztec Symbol



Codabar

Read the following symbols to enable/disable **Codabar** settings:

Codabar On (Default)



M275_01

Codabar Off



M274_01

Codabar by ESP

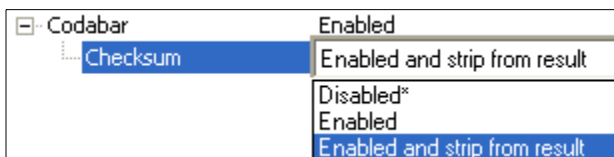

ESP allows you to enable a checksum, or to enable a check sum and remove it from the decode result.

Sample Codabar Symbol



A123456789A

Codablock A / Codablock F

Read the following symbols to enable/disable **Codablock A** and **Codablock F** settings:

Codablock A On



M760_01

Codablock A Off (Default)



M759_01

Codablock F On



M277_01

Codablock F Off (Default)



M276_01

Codablock by ESP

Codablock A	Disabled
Codablock F	Disabled*
	Disabled*
	Enabled

Important: When Codablock F and Code 128 are both enabled, there is some risk of mistakenly decoding a damaged Codablock F symbol as a Code 128 symbol. Therefore, whenever possible, Code 128 should be disabled when Codablock F is enabled.

Using **Codablock F On** will disable Code 128. Using **Codablock F Off** will re-enable Code 128.

Sample Codablock F Symbol



Code 11

Read the following symbols to enable/disable **Code 11** settings:

**Code 11 Enabled with 2
Checksum Digits**



M394_01

**Code 11 Disabled
(Default)**



M393_01

**Enabled with 1 Checksum
Digit**



M395_01

**Enabled with 2 Checksum Digits
and Stripped from Result**



M396_01

**Enabled with 1 Checksum Digit
and Stripped from Result**



M397_01

Code 11 by ESP

Note: “No Report” in **ESP** has the same meaning as “Stripped from Result”.

Code 11	Disabled*
	Disabled*
	Enabled with 2 checksum digits
	Enabled with 1 checksum digit
	Enabled with 2 checksum digits no report
	Enabled with 1 checksum digit no report

Sample Code 11 Symbol

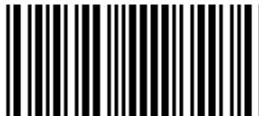

Code 39

Read the following symbols to enable/disable **Code 39** settings:

Code 39 On (Default)



M235_01

Code 39 Off



M234_01

Enable Checksum



M237_01

Disable Checksum (Default)



M236_01

Enable Checksum and Strip from Result



M238_01

**Code 39 Extended
Full ASCII On**



M233_01

**Code 39 Extended
Full ASCII Off (Default)**



M232_01

Code 39 Narrow Margins On



M390_01

Code 39 Narrow Margins Off (Default)



M389_01

Code 39 Trioptic On (Default)



M671_01

Code 39 Trioptic Off



M670_01

Code 39 by ESP

Code 39	Enabled
Checksum	Enabled and strip from result
Extended Full ASCII	Disabled*
Narrow Margins	Enabled
Code 39 Trioptic	Enabled and strip from result

Sample Code 39 Symbol



Sample Code 39 Trioptic Symbol



Code 93

Read the following symbols to enable/disable **Code 93** settings:

Code 93 On (Default)



M281_02

Code 93 Off



M280_01

Code 93 by ESP

Code 93	Enabled*
	Disabled
	Enabled*

Sample Code 93 Symbol



123456789A

Code 128

Read the following symbols to enable/disable **Code 128** settings:

Code 128 On (Default)



M283_01

Code 128 Off



M282_01

Code 128 Narrow Margins On



M392_01

Code 128 Narrow Margins Off (Default)



M391_01

Code 128 by ESP

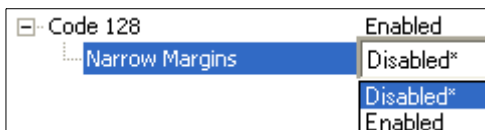

Sample Code 128 Symbol



123456789A

Composite

To read **Composite** symbols:

1. Enable the corresponding linear component.
2. Read the **Composite On** symbol below.
3. Set **Maximum Decodes per Read** to **2**.

Important: Both the applicable linear symbology portion of the Composite symbol as well as **Composite On** must be enabled before the reader can fully decode a Composite symbol.

Composite On



Composite Off (Default)



Composite by ESP

Composite Linkage Control

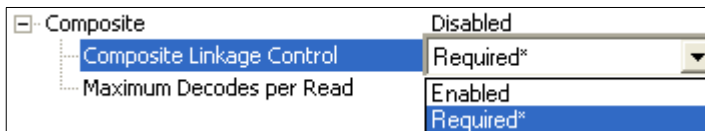

When **Composite Linkage Control** is set to **Required**, symbol data will only be output if both the 2D and 1D components of the symbol are decoded. When not required, symbol data will be output even when only one of the components is decoded.

Maximum Decodes per Read



Maximum Decodes per Read represents the maximum number of candidate symbols in the field of view that can be decoded during a read cycle. Note that decode speed will decrease as the **Maximum Decodes per Read** value is increased.

Data Matrix

Read the following symbols to enable/disable **Data Matrix** settings:

**Data Matrix
Rectangle On**



M242_01

**Data Matrix
Rectangle Off
(Default)**



M241_01

**Data Matrix
Inverse On**



M239_01

**Data Matrix
Inverse Off
(Default)**



M240_01

Data Matrix ECC 0-140 On



Q005_01

Data Matrix ECC 0-140 Off (Default)



Q006_01

**Enable Data Matrix Improvements
(Low Contrast and Binarized Symbols)**



M744_01

Disable Data Matrix Improvements (Default)



M745_01

Sample Data Matrix Symbol



Sample Rectangular Data Matrix Symbol



Data Matrix by ESP

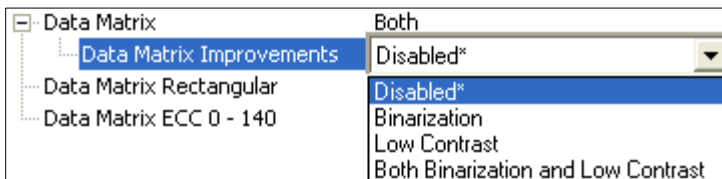

Interleaved 2 of 5

Read the following symbols to enable/disable **Interleaved 2 of 5** settings:

Interleaved 2 of 5 On (Default)



M244_01

Interleaved 2 of 5 Off



M243_01

Interleaved 2 of 5 Two Digits On



M246_01

Interleaved 2 of 5 Two Digits Off



M245_02

Interleaved 2 of 5 Four Digits On



M248_01

Interleaved 2 of 5 Four Digits Off



M247_01

Interleaved 2 of 5 by ESP

Interleaved 2 of 5	Enabled
Checksum	Disabled
Length	2 Digit Disabled*
Straight 2 of 5	2 and 4 Digit Disabled
	2 Digit Enabled
	4 Digit Enabled
	2 Digit Disabled*
	2 Digit Enabled 4 Digit Disabled
	2 Digit Disabled 4 Digit Enabled
	2 and 4 Digit Enabled

Sample Interleaved 2 of 5 Symbol



Maxicode

Read the following symbols to enable/disable **Maxicode** settings:

Maxicode On



Maxicode Off (Default)



Maxicode by ESP

Maxicode	Disabled*
	Disabled*
	Enable Modes 0 - 3
	Enabled (All)
	Mode 0
	Mode 1
	Mode 2
	Mode 3
	Mode 4
	Mode 5
	Mode 6

Mode 0 = Reserved

Mode 1 = Reserved

Mode 2 = **US Carrier** with postal symbols up to 9 digits in length.

Mode 3 = **International Carrier** with alphanumeric postal symbols up to 6 characters in length.

Mode 4 = **Standard Symbol** – Use this mode to encode information for purposes other than the shipping industry. Up to approximately 90 characters can be encoded in this mode.

Mode 5 = **Secure Symbol** – Use this option to encode information with additional error correction. Up to approximately 74 characters can be encoded in this mode.

Mode 6 = **Reader Program** – This option allows scanner manufacturers to program their scanners.

Sample Maxicode Symbol



Matrix 2 of 5

Read the following symbols to enable/disable **Matrix 2 of 5** settings:

Matrix 2 of 5 On (Default)



Matrix 2 of 5 Off



Matrix 2 of 5 by ESP

Matrix 2 of 5	Disabled
	Disabled
	Enabled*
	Enable Checksum
	Enable Checksum not output
	Enable decode 1 digit symbol
	Enable decode 2 digit symbol
	Enable decode 1 and 2 digit symbol
	Enable decode 1 digit with checksum
	Enable decode 2 digit with checksum
	Enable decode 1 and 2 digit with checksum
	Enable decode 1 digit w checksum not output
	Enable decode 2 digit w checksum not output
	Enable decode 1, 2 digit w checksum not output

Sample Matrix 2 of 5 Symbol



MicroPDF417

Read the following symbols to enable/disable **MicroPDF417** settings:

MicroPDF417 On



M301_01

MicroPDF417 Off (Default)



M300_01

MicroPDF417 by ESP

Micro PDF417	Disabled*
	Disabled*
	Enabled

Sample MicroPDF417 Symbol



MSI Plessey

Read the following symbols to enable/disable **MSI Plessey** settings:

MSI Plessey On



M291_01

MSI Plessey Off (Default)



M290_01

MSI Plessey by ESP

MSI Plessey	Disabled*
	Disabled*
	Enabled

Sample MSI Plessey Symbol



NEC 2 of 5

Read the following symbols to enable/disable **NEC 2 of 5** settings:

NEC 2 of 5 On (Default)



M673_01

NEC 2 of 5 Off



M672_01

NEC 2 of 5 by ESP

NEC 2 of 5	Disabled
	Disabled
	Enabled*
	Enable Checksum
	Enable Checksum not output
	Enable decode 1 digit symbol
	Enable decode 2 digit symbol
	Enable decode 1 and 2 digit symbol
	Enable decode 1 digit with checksum
	Enable decode 2 digit with checksum
	Enable decode 1 and 2 digit symbol
	Enable decode 1 digit w checksum not output
	Enable decode 2 digit w checksum not output
	Enable decode 1, 2 digit w checksum not output

Sample NEC 2 of 5 Symbol



PDF417

Read the following symbols to enable/disable **PDF417** settings:

PDF417 On (Default)



M293_01

PDF417 Off



M292_01

MacroPDF417 On



M287_01

MacroPDF417 Off (Default)



M286_01

PDF417 by ESP

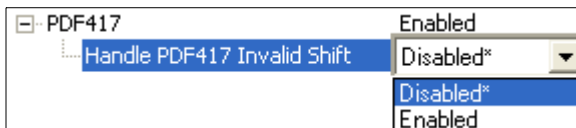

Sample PDF417 Symbol



Pharmacode

Read the following symbols to configure **Pharmacode** settings:

Pharmacode On;
No Color, Standard Rules, Horizontal Decode, Normal Direction



M409_01

Pharmacode On;
Color, Relaxed Contrast, Horizontal Decode, Normal Direction



M410_01

Pharmacode On;
No Color, Standard Rules, Vertical Decode, Normal Direction



M411_01

Pharmacode On;
Color, Relaxed Contrast, Vertical Decode, Normal Direction



M412_01

Pharmacode On;
No Color, Standard Rules, Horizontal Decode, Reverse Direction



M413_01

Pharmacode (cont.)

Pharmacode On;
Color, Relaxed Contrast, Horizontal Decode, Reverse Direction



M414_01

Pharmacode On;
No Color, Standard Rules, Vertical Decode, Reverse Direction



M415_01

Pharmacode On;
Color, Relaxed Contrast, Vertical Decode, Reverse Direction



M416_01

Pharmacode Off (Default)



M408_01

Pharmacode by ESP

Pharmacode	Disabled*
Minimum and Maximum Bars	Disabled*
Minimum Value	Enabled; no color bars; std rules; horiz; normal
Maximum Value	Enabled; color bars; relaxed rules; horiz; normal
	Enabled; no color bars; std rules; Vert; normal
	Enabled; color bars; relaxed rules; Vert; normal
	Enabled; no color bars; std rules; horiz; reverse
	Enabled; color bars; relaxed rules; horiz; reverse
	Enabled; no color bars; std rules; Vert; reverse
	Enabled; color bars; relaxed rules; Vert; reverse

Sample Pharmacode Symbol

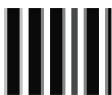

121

QR Code

Read the following symbols to enable/disable **QR Code** settings:

Standard QR Code On



M261_01

QR Code Off (Default)



M260_01

Inverse On



M262_01

Inverse and Standard On



M263_01

All QR Code On



M609_03

Inverse and Micro QR On



M687_03

QR Code by ESP

QR Code	Disabled*
	Disabled*
	Standard
	Inverse
	Both
	Micro QR Code
	QR Code and Micro Code
	Inverse Micro QR Code
	Inverse QR Code and Inverse MicroQR Code
	Enable All QR

Sample QR Code Symbol



Sample Micro QR Code Symbol



GS1 DataBar

Read the following symbols to enable/disable **DataBar** settings:

DataBar Limited On



M268_01

DataBar-14 and DataBar-14 Truncated On



M271_01

DataBar-14 Stacked On



M270_01

DataBar Expanded On



M269_01

All DataBar On



M267_01

All DataBar Off (Default)



M266_01

GS1 DataBar by ESP

RSS	Disabled*
	Disabled*
	RSS Expanded
	RSS Expanded Stacked
	RSS Limited
	RSS-14 Stacked and RSS-14 Stacked Omnidirectional
	Enabled (All)

Sample DataBar-14 Truncated Symbol



Sample DataBar-14 Stacked Symbol



Sample DataBar Expanded Symbol



Sample DataBar-14 Symbol



UPC/EAN/JAN

Read the following symbols to enable/disable **UPC/EAN/JAN** settings:

UPC On (Default)



M295_01

UPC Off



M294_01

UPC Narrow Margins On



M299_01

UPC Narrow Margins Off (Default)



M298_01

Note: Unless necessary, enabling **Narrow Margins** are not recommended.

UPC Extension On



M297_01

UPC Extension Off (Default)



M296_01

UPC/EAN/JAN by ESP

UPC	Enabled
Expansion	Enabled
Supplementals	Enabled
Narrow Margins	Disabled*
	Disabled*
	Enabled

Sample UPC-E Symbol



Symbology Identifier

When **Symbology Identifier** is enabled, an AIM (Association for Automatic Identification and Mobility) preamble is added to decoded data output (see [AIM Symbology Identifiers](#)). This preamble identifies what kind of symbology has been decoded.



M226_01

Symbology Identifier On



M225_01

Symbology Identifier Off (Default)

Symbology Identifier by ESP

Symbology Identifier	Disabled*
	Disabled*
	Enabled

AIM Symbology Identifiers

A	Code 39
B	Telepen
C	Code 128
d	Data Matrix
e	GS1 DataBar
E	UPC/EAN
F	Codabar
G	Code 93
H	Code 11
I	Interleaved 2 of 5
L	PDF417
M	MSI Code
O	Codablock
p	Pharmacode
P	Plessey Code
Q	QR Code / Micro QR Code
X	Other Symbology
z	Aztec
Z	Non-Barcode Data

Modifier Characters

Modifier characters are determined by adding the option values of each symbology. If the sum is larger than 9, use A, B, C, D, E, or F in place of 10, 11, 12, 13, 14, and 15.

Code 39 Option Values

0	No check character or full ASCII
1	Reader has performed mod 43 check
2	Reader has performed mod 43 check and stripped the check character
4	Reader has performed full ASCII conversion

Telepen Option Values

0	Full ASCII mode
1	Double-density numeric mode
2	Double-density numeric followed by full ASCII
4	Full ASCII followed by double-density numeric

Code 128 Option Values

- 0** Standard
- 1** Function code 1 in first character position
- 2** Function code 2 in second character position. Concatenation according to ISBT.
- 4** Specification has been performed and concatenated data follows.



6 I/O Parameters

Contents

I/O Parameters by ESP.....	6-2
HS-2D Operational Feedback.....	6-3
Automatic Gain Control (AGC).....	6-4
Image Quality.....	6-5

This section contains information on how to set your reader to the most efficient and effective parameters for your application.

I/O Parameters by ESP

To make changes to configuration settings in the **I/O Parameters** menu tree control:

1. **Left click** on the **+** to expand the tree.

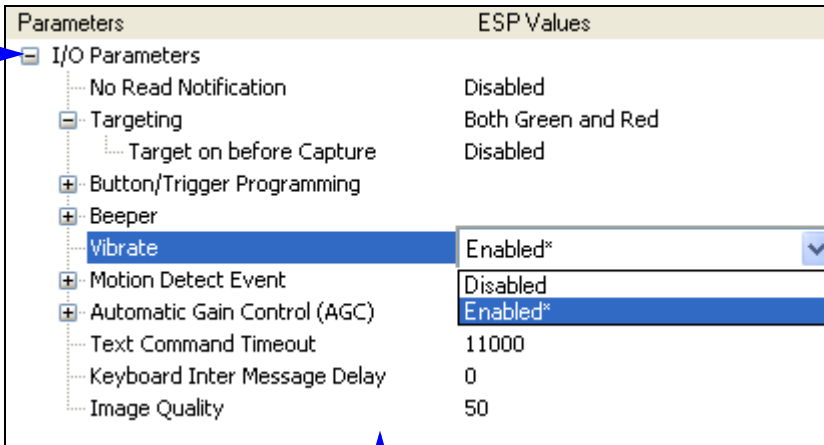

2. **Double click** on the parameter and click once in the selection box to view options.
3. Place your cursor in the selection box, scroll down to the setting you want to change and **click once** on the setting.

4. **Left click** again on the open screen to complete the selection.
5. **Right click** on the open screen and select **Save to Reader** to implement the command in the reader.

HS-2D Operational Feedback

Condition	Sound/Vibration	LED
Successful Power-On	1 Beep / Vibration	Sequence: AMBER GREEN AMBER
Successful Connection with Host via USB	1 Beep / Vibration	None
Successful Decode and Data Transfer to Host	1 Beep / Vibration	Flash GREEN
Configuration Symbol Successfully Decoded and Processed	2 Beeps / Vibrations separated by short pause	Flash GREEN

Beep and Vibration Modes

Read the following symbols to set beep and vibration modes.



M107_01

**Vibrate On /
Beep On
(Default)**



M109_01

**Vibrate On /
Beep Off**



M108_01

**Vibrate Off /
Beep On**

Automatic Gain Control (AGC)

AGC is a system that controls gain in order to maintain high performance over a range of input levels. Gain is essentially the ratio of output to input. Gain settings affect how the HS-2D decodes symbols and captures images.

AGC Frame Adjust Count



A screenshot of a control interface for the AGC Frame Adjust Count. It features a blue header with the text "AGC Frame Adjust Count", a white input field containing the number "0", a small vertical slider control, and a light green box containing the text "Frames".

AGC Frame Adjust Count sets the number of image frames captured and discarded before the main image capture. This feature gives the gain control time to adjust.

Image Quality

Image Quality allows the user to adjust the quality and size of images captured by the reader.

1 represents the lowest possible image quality and size, and **75** represents the highest possible image quality and size.



■ **7 *Advanced Operations***

Contents

Continuous Operations.....	7-2
Lock Settings	7-3
Button Stay-Down Time.....	7-4
Mirroring	7-5
Motion Detection.....	7-6

This section introduces several settings that can be applied to speed up processing or improve readability in various circumstances.

Continuous Operations

Continuous Read

Read the following symbols to enable or disable Continuous Read.



M140_02

Continuous Read On



M141_03

Continuous Read Off

Continuous Read, Trigger Delays

Read the following symbols to set the delay time between decodes.



M142_01

**0 Seconds
(Default)**



M143_01

1 Second



M144_01

3 Seconds

Continuous Read, Duplicate Read Delays

Read the following symbols to determine the time interval between a decode and the rejection of a subsequent duplicate decode.



M222_01

**0 Seconds
(Default)**



M223_01

1 Second



M224_01

3 Seconds

Lock Settings

Read the symbols below to lock or unlock reader settings.

Note: This feature does not lock preamble and postamble programming symbols, Clear XML Rules, or postamble erase/none commands.



M429_01

***Lock Reader
Settings***



M428_01

***Unlock Reader
Settings***

Button Stay-Down Time

Button Stay-Down Time sets the amount of time (in seconds) that the reader will continue to process the current “decode symbol” event. The reader will behave as if the trigger is being activated for this specified amount of time.

Parameters	ESP Values
[-] Read Cycle	
[-] Default Continuous Event	Idle
Event Delay	0
Read Cycle Timeout	450
Button Stay-Down Time	0.000 Seconds
Ignore Duplicate Symbol Timeout	0
Targeting Zone Tolerance	1600
Continuous Illumination	On between reads

Available **Button Stay-Down Time** values are 0.000 to 2147483.750 (in seconds).

Mirroring

Mirroring allows the HS-2D to decode symbols that are reversed. When Mirroring is enabled, all other decode functionality is disabled.

Note: Once the reader has been set to **Mirroring On**, it can only return to its default mode by reading the **Mirroring Off** symbol below.

Mirroring On



Mirroring Off (Default)

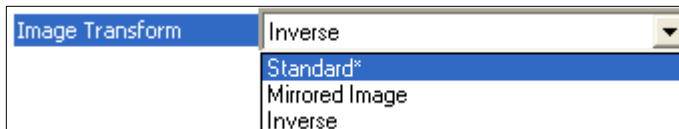

Image Transform

In **ESP**, the **Mirroring** feature is part of the **Image Transform** command.

When Image Transform is set to **Standard**, **Mirrored Image** is disabled.

When Image Transform is set to **Mirrored Image**, the HS-2D's optics reverse the captured image before attempting to decode.



Motion Detection

Motion Detection causes the HS-2D to attempt a decode whenever it senses motion in its field of view.

Motion Detection On



M701_01

Motion Detection Off (Default)



M702_01

Motion Detection by ESP

Motion Detection settings can be refined further using the options in **ESP**.

<input type="checkbox"/> Motion Detect Event	Disabled*
Motion Sensitivity	Disabled*
Button Stay-Down Time	Read Near Field

Select the action you want the HS-2D to perform when it detects motion in the field of view.

Motion Sensitivity

The HS-2D's sensitivity to motion in the field of view can be configured as shown below.

Note: The lower the number, the greater the sensitivity.

Motion Sensitivity	50	(0 - 2147483647)
--------------------	----	------------------

Note: For **Motion Sensitivity** to function correctly, Button Stay-Down Time should be increased.



8 Terminal

Contents

- Terminal View..... 8-2
- Find 8-3
- Send 8-4
- Macros..... 8-5
- Terminal Right-Click Menu..... 8-6
- Terminal Dropdown Menu..... 8-7

This section describes the **Terminal** interface and macro functions in **ESP**.

Terminal View

Click the **Terminal** button.



You will see the following view:

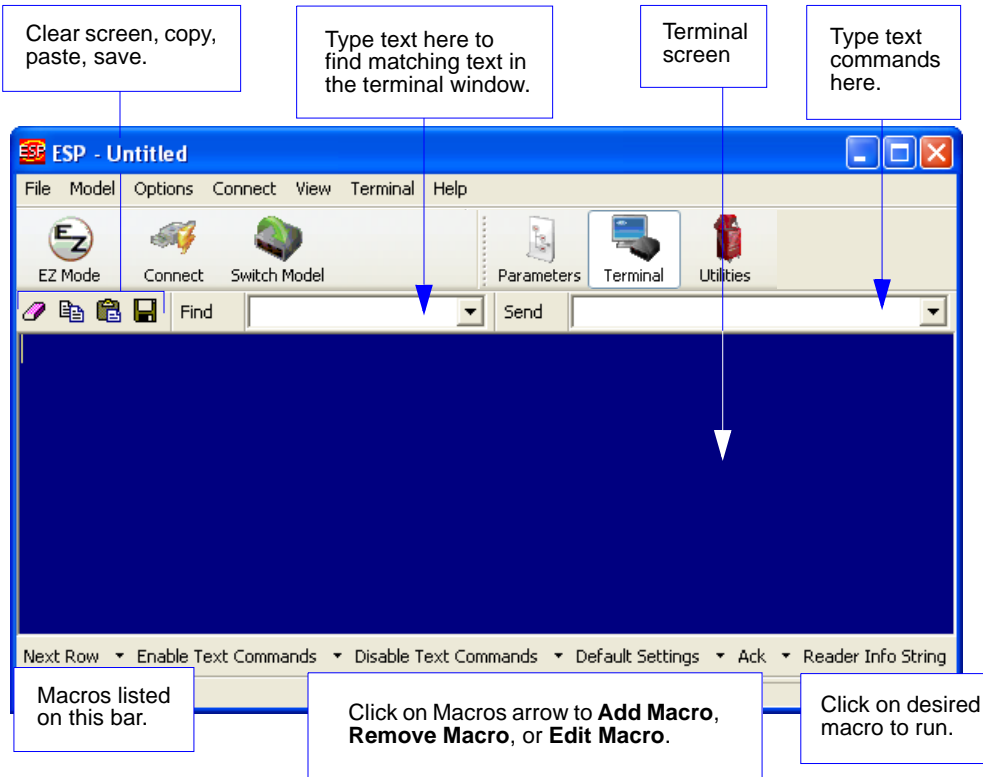

The screenshot shows the 'ESP - Untitled' window with a menu bar (File, Model, Options, Connect, View, Terminal, Help) and a toolbar (EZ Mode, Connect, Switch Model, Parameters, Terminal, Utilities). Below the toolbar is a 'Find' field and a 'Send' field. The main area is a large blue terminal screen. At the bottom, there is a status bar with options like 'Next Row', 'Enable Text Commands', 'Disable Text Commands', 'Default Settings', 'Ack', and 'Reader Info String'. Callout boxes provide instructions: 'Clear screen, copy, paste, save.' points to the 'Terminal' button; 'Type text here to find matching text in the terminal window.' points to the 'Find' field; 'Terminal screen' points to the blue terminal area; 'Type text commands here.' points to the 'Send' field; 'Macros listed on this bar.' points to the status bar; 'Click on Macros arrow to Add Macro, Remove Macro, or Edit Macro.' points to the 'Next Row' dropdown; and 'Click on desired macro to run.' points to the 'Reader Info String' dropdown.

The Terminal interface allows you to send commands to the reader by using macros, by copying and pasting, or by typing commands in the **Send** text field.

The Terminal view also displays symbol data or information from the reader.

You can also right click on the Terminal screen to bring up a menu of further options.

Find

The **Find** function allows you to enter text strings to be searched for in the terminal window. For example, suppose a series of symbols have been scanned into the terminal view and you want to determine if a particular symbol whose data begins with “ABC” has been read.

1. Type “ABC” into the **Find** box.

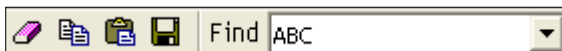

2. Press **Enter**.

The first instance of “ABC” will be highlighted in the terminal window.

3. Click the **Find** button to the left of the text field to locate additional instances of “ABC”.

Send

The **Send** function allows you to enter text commands and then send them to the reader. (See [Text Commands](#).)

For example, suppose you want to disable the vibrate function in the reader. To disable vibrate using a text command, you would enter “P%A10” (the command that disables vibrate) in the text field and click **Send**.

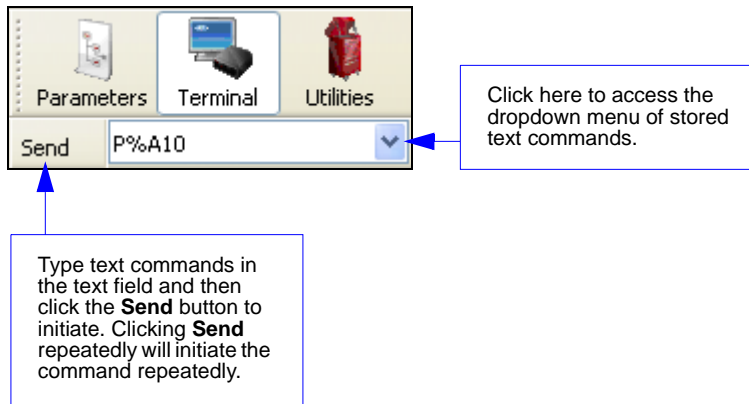

Once text commands are initiated, they are saved in a dropdown menu that can be accessed by clicking the arrow to the right of the text field.

You can also send the current command repeatedly by clicking the **Send** button repeatedly.

Macros

Macros can be stored in a macro selection bar, edited in a separate window, and executed by clicking on the macro name.

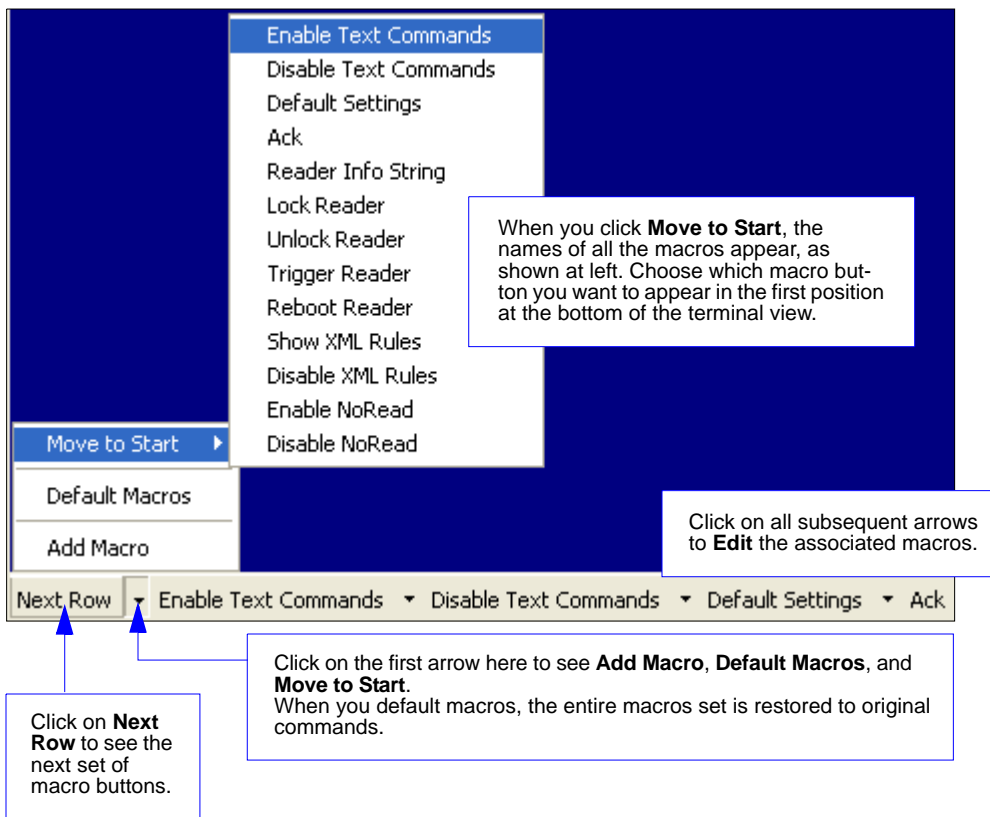

Clicking on a macro button executes the related command. The command is also sent to the reader at the same time it is displayed.

Editing a Macro

When you click the arrow next to a any macro and select **Edit**, the following dialog appears:

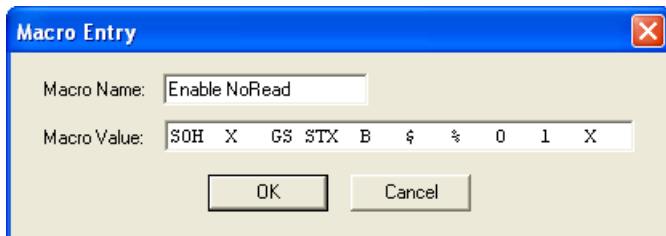

You can edit an existing macro or type in the **Macro Name** text field and define it in the **Macro Value** text field.

Terminal Right-Click Menu

Right click in the terminal window to display the following menu:

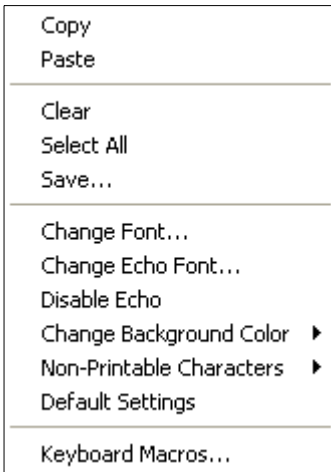

- **Copy** selected text to clipboard.
- **Paste** from terminal or other text.
- **Clear** all text in terminal window.
- **Select All** text in the terminal window.
- **Save...** incoming and outgoing data into a text file.
- **Change Font...** of data received from the reader.
- **Change Echo Font...** to change the appearance of user-entered data.
- **Disable Echo** to hide user-entered data.
- **Change Background Color** of the terminal window.
- **Non-Printable Characters** can be shown or hidden in the terminal view in **Standard** or **Enhanced** format.
- **Default Settings** to return all of the above to original settings.
- **Keyboard Macros** brings up the **Function Keys** dialog, which allows you to create customized macro functions.

Function Keys

The **Function Keys** dialog allows you to assign commands to specific function keys on a standard keyboard. Note that the **F1** key is reserved for opening **ESP Help**, and the **F3** key is reserved for the **Find Next** function.

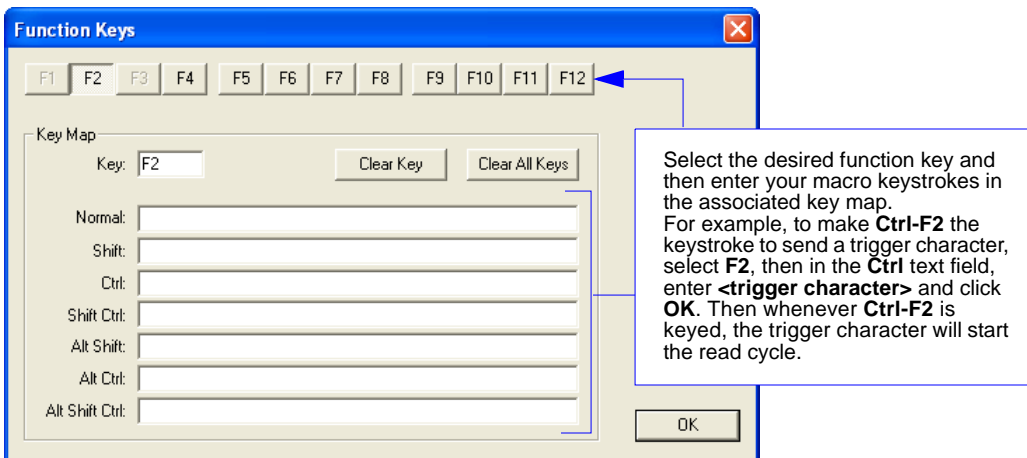

Note: This feature is also available from the **Terminal Dropdown Menu** and the **Terminal** tab of the **Preferences** dialog.

Terminal Dropdown Menu

The terminal dropdown menu allows you to capture and save current text, and it also includes the functions defined for the [Terminal Right-Click Menu](#).

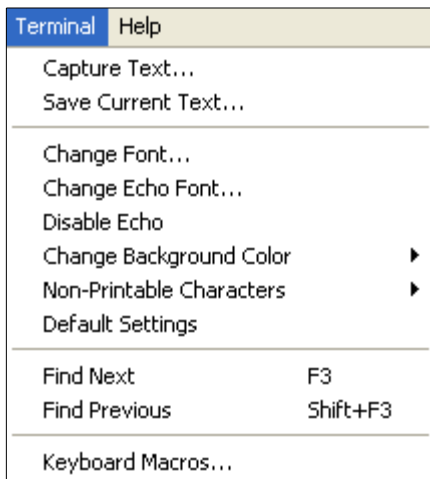

- **Capture Text...** lets you append data in real time to a text file of your choice. While in operation, the text file cannot be opened. You can select **Pause** to interrupt the capture flow or **Stop** to end the flow and open the file.
- **Save Current Text...** saves all text in the terminal window to a text file of your choice.
- **Find Next** locates the next instance of the specified data string in the terminal. This function can also be activated by pressing **F3**.
- **Find Previous** locates the most recently occurring instance of the specified data string in the terminal.
- **Keyboard Macros** brings up the **Function Keys** dialog, which allows you to create customized macro functions.



9 Utilities

Contents

Device Control.....	9-2
Differences from Default	9-3
Firmware	9-4
Advanced	9-6

This section explains **ESP's Utilities** features. These include **Device Control**, an interface that lets you perform major operations with one click; **Differences from Default**, which shows all currently enabled HS-2D settings that are not default settings; **Firmware**, where you can update your reader's firmware; and **Advanced**, which allows you to collect batch files for customized reader configuration and optimization.

Device Control

This feature allows you to clear data stored in the reader's memory, to default the reader, to deactivate or clear XML rules, to upload or delete stored errors, to reboot the reader, and to delete stored results.

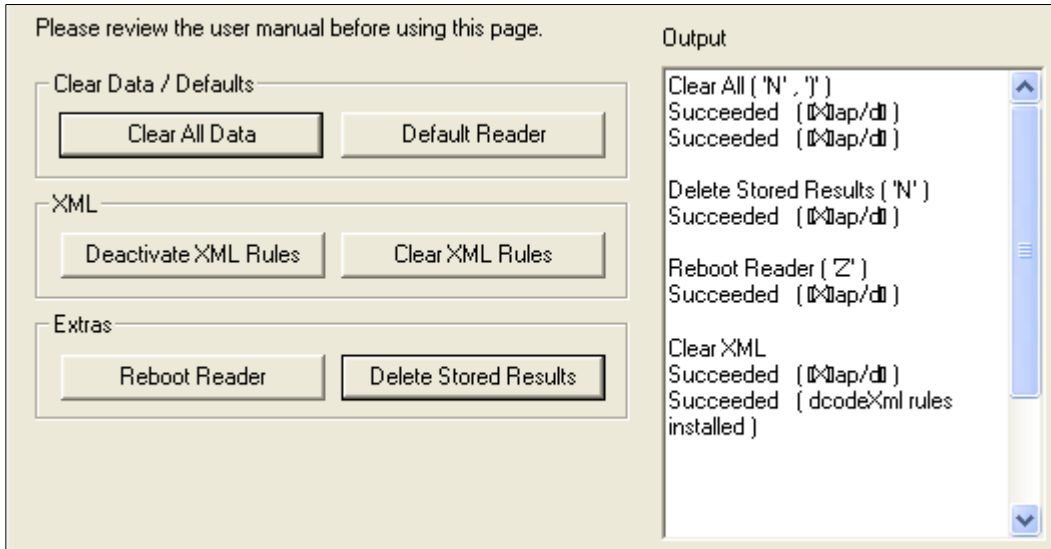

- **Clear All Data** removes decoded symbol data and commands in the reader's memory.
- **Default Reader** returns the reader to its default state, without any optimization or configuration.
- **Deactivate XML Rules** turns off, but does not erase, preambles, postambles, and XML commands.
- **Clear XML Rules** removes preambles, postambles, and other XML commands.
- **Reboot Reader** refreshes the reader's memory and functionality, returning it to the most recent configuration you have saved.
- **Delete Stored Results** erases logged data.

Firmware

The **Firmware** view in **ESP Utilities** is a simple way to update and verify your reader's firmware and to update batch files.

Choose **App Code** from the **Firmware Update** dropdown menu and click **Start** to install new firmware in the HS-2D.

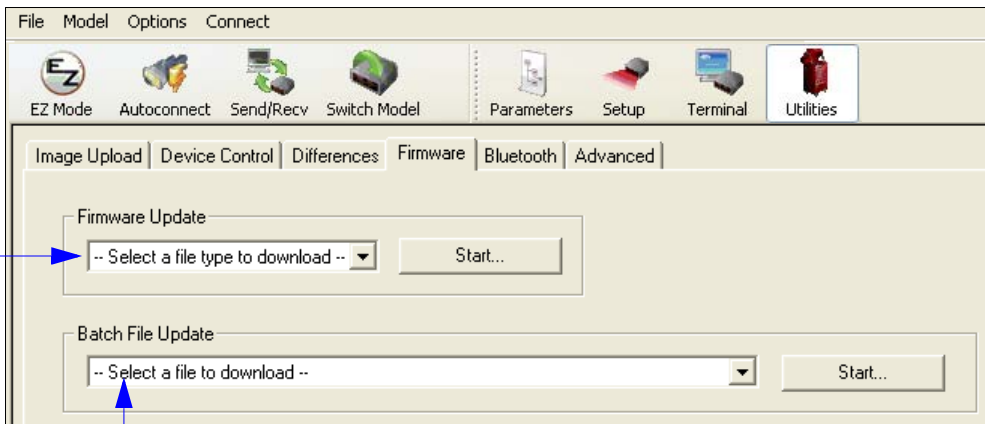

Use this dropdown menu to locate batch files in the host computer's file directory. Download the needed files directly to the reader by clicking the **Start** button.

The **Firmware Verification** tool sends a direct query to the reader for its Application Code Version, Firmware Version, and Boot Code Version.



Reader ID

Another way to query the reader for its identifying information is by reading the following symbol:



Reader ID

The host's text program will output a data string containing the reader's identifying information in the following format:

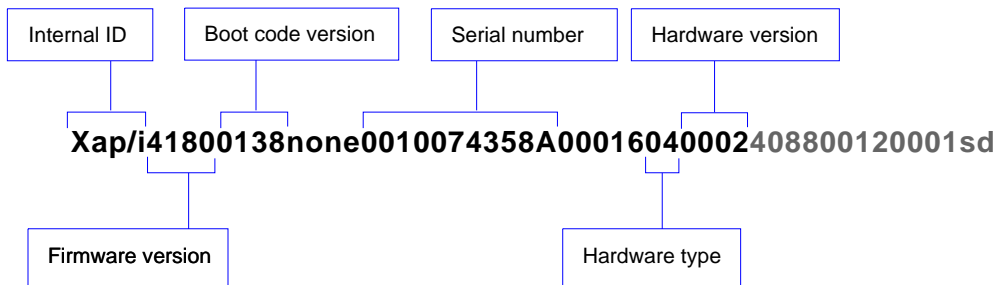

Advanced

The **Advanced** tab in **Utilities** features an archive of all batch files containing reader configuration commands. Each batch file's extension is .crb, and each file contains the fundamental code for programming the reader. Notice that the names of the batch files correspond with the numbers beneath all the Data Matrix configuration symbols.

This tool allows you to use the batch file data to create your own symbols, or to collect only the files that you use frequently to configure the reader for your application.

The screenshot shows the 'Advanced' tab in the Utilities application. It features three main windows: 'Batch File Archive', 'Batch File Collection', and 'Batch File Creator'. The 'Batch File Archive' window contains a list of batch files with columns for 'Batch File' and 'Description'. The 'Batch File Collection' window is empty. The 'Batch File Creator' window has 'Download Collection' and 'Save Collection As...' buttons. Callout boxes explain the 'Add' and 'Remove' buttons and the 'Download Collection' and 'Save Collection As...' buttons.

Batch File Archive

Batch File	Description
M157_01	Handle Trigger - R...
M158_02	Handle Trigger - U...
M159_02	Prefix - Comma
M160_04	Suffix - Comma
M161_04	Suffix - Enter
M162_01	Prefix Erase None
M163_01	Suffix - Erase / No...
M164_02	Prefix - Space
M165_04	Suffix - Space
M166_01	Prefix - Tab - Keyb...
M167_04	Suffix - Tab - Keyb...
M168_04	Suffix - Carriage R...
M169_04	Suffix - Line Feed ...
M170_04	Suffix - Carriage R...
M171_01	Custom Keyboard
M172_01	US Keyboard Map...
M173_01	Universal Keyboar...
M174_01	Control LED's Sep...
M175_01	Control LED's Sep...
M176_01	Left Trigger - Rea...
M177_01	Left Trigger - Rea...
M178_01	Left Trigger - Rea...
M179_01	Left Trigger Take ...
M180_02	Left Trigger - Uplo...
M181_01	Mirroring - Off
M182_01	Mirroring - On
M183_01	Right Trigger - Re...
M185_01	Right Trigger - Re...
M186_01	Right Trigger Tak...
M187_02	Right Trigger - Up...
M189_01	Set Targeting Zon...
M190_01	Set Targeting Zon...
M191_01	Set Targeting Zon...
M192_01	Set Targeting Zon...
M193_01	Set Targeting Zon...
M194_01	Set Targeting Zon...
M195_01	Set Targeting Zon...
M196_01	Set Targeting Zon...
M197_01	Reader Text Com...
M198_01	Reader Text Com...
M199_01	Time Stamp Settin...
M200_01	Time Stamp Settin...
M201_02	Enable SXGA - 12...

Batch File Collection

Batch File	Description
M184_01	Right Trigger - Read ...
M188_02	Save Settings

Batch File Creator

Download Collection

Save Collection As...

The **Download Collection** and **Save Collection As...** buttons allow you to acquire the entire contents of the batch file archive and save the files in a location of your choice.

Scroll through the list of batch files in the archive and choose the ones you need. Move them to the collection window using the **Add** arrow. Files can also be transferred by clicking and dragging.

The single **Remove** arrow functions in the same way as the **Add** arrow, except that it transfers files back to the batch archive. The double **Remove** arrow allows you to transfer all files simultaneously.

Appendices

Appendix A General Specifications	A-2
Appendix B Electrical Specifications	A-3
Appendix C HS-2D Maintenance.....	A-6

Appendix A — General Specifications

Mechanical

Height:	7" (180 mm)
Width:	2.5" (63 mm)
Depth:	4.5" (114 mm)
Weight:	6.4 oz. (181 g) (not including cable)

Environmental

Operating temperature: 0° to 50°C
(32° to 122°F)

Storage temperature: -20° to 65° C
(-4° to 150°F)

Humidity: 5 to 95% (non-condensing)

Shock: Withstands multiple drops of 6' (1.8 meters) to concrete

CE Standards

Immunity: EN 55024

ESD: EN 61000-4-2

Radiated RF: EN 61000-4-3

Keyed Carrier: ENV 50204

EFT: EN 61000-4-4

Conducted RF Immunity: EN61000-4-6

Emissions: EN55022, Class B Radiated,
Class B Conducted

Symbologies

2D Symbologies: Data Matrix, Aztec, QR Code, Micro QR Code, Maxicode

Stacked Symbologies: PDF417, MicroPDF417, GS1 DataBar (Composite and Stacked)

Linear Symbologies: Code 39, Code 128, Code 11, Interleaved 2 of 5, Matrix 2 of 5, NEC 2 of 5, UPC/EAN, Codabar, MSI Plessey, Codablock F, Pharmacode, Code 93

Light Collection Options

Sensor: CMOS, progressive scan, 1.33 MP, 256 grayscale

Sensor Array: 1280 by 1024

Field of View: 43.48° horizontal by 31.86° vertical

Focal Point: Optimal at 2.3" (5.8 cm)

Communication Protocols

Standard Interface: USB, RS-232

Read Parameters

Pitch: ±60° (front to back); *Skew:* ±60°; *Rotational Tolerance:* ±180°

Focal Range: .5 to 6" (12 to 152 mm)

Print contrast Resolution: 25% (1D symbols); 35% (PDF417); absolute dark/light reflectance differential, measured at 650 nm

Ambient Light Immunity: Sunlight: Up to 9,000 ft. candles, 96,890 lux

Indicators

Status Indicators: Vibration motor, audible tones, visual feedback with multi-color LED

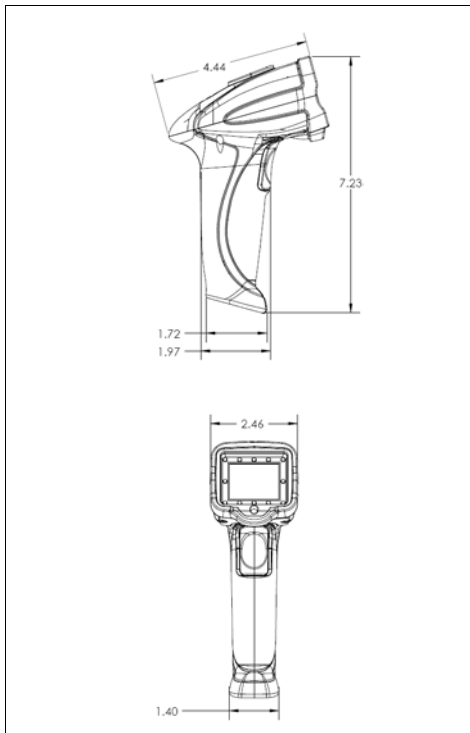

HS-2D Dimensions

Image Output Options

Format: JPEG, raw (uncompressed)

Safety Certifications

FCC, CE, RoHS/WEEE



ISO 9001 Certified
Issued by TÜV USA
Copyright ©2011
Microscan Systems, Inc.

All rights reserved. Specifications subject to change. Product specifications are given for typical performance at 25°C (77°F) using grade A labels. Performance characteristics may vary at high temperatures or other environmental extremes. Warranty—One year limited warranty on parts and labor. Extended warranty available.

Read Ranges

Narrow Bar Width	Read Range
.0063" (.160 mm)	1.50 to 2.5" (32 mm to 64 mm)
.0083" (.211 mm)	1.75 to 3.2" (44 mm to 81 mm)
.020" (.508 mm)	.50 to 5.2" (13 mm to 132 mm)

Read ranges based on Grade A Data Matrix symbols. Data subject to change.

Appendix B — Electrical Specifications

Power Requirements: 5 VDC (mA)

Typical: 330 mA; Peak: 345 mA, Idle: 250 mA

PIN 1	VIN- Input Voltage to the voltage regulators/battery charging IC
PIN 2	RS-232_TX - RS-232 level serial transmit signal
PIN 3	RS-232_RX - RS-232 level serial receive signal
PIN 4	PS/2_DATA_UART_RX_USB_DP - PS/2 clk to host/ UART transmit signal/ USB Data plus signal
PIN 5	PS/2_DATA_UART_RX_USB_DM - PS/2 data to host or keyboard/ UART receive signal/ USB Data minus signal
PIN 6	PS/2_CLK_KB - PS/2 clock signal to the keyboard
PIN 7	~TRIG - trigger from the handle
PIN 8	GND - signal ground
Shield	Shield Ground

USB Cable Pinouts

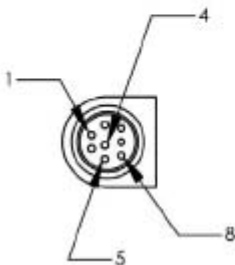
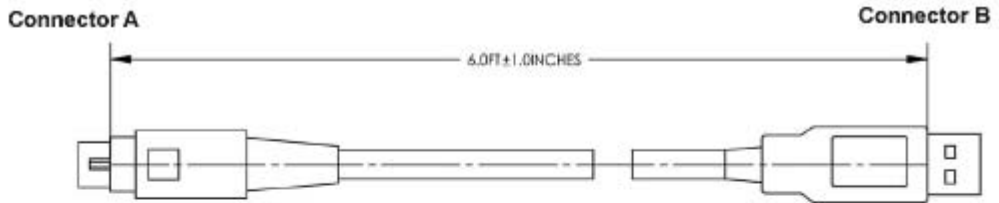

WIRING TABLE:

CONN A	NAME	WIRE	COLOR	CONN B
1	V+	24AWG	RED	1
2	NC			
3	NC			
4	D+	28AWG	GREEN (TWISTED)	3
5	D-	28AWG	WHITE (TWISTED)	2
6	NC			
7	NC			
8	GND	24AWG	BLACK	4
SHELL	--	DRAIN	BARE	SHELL

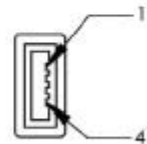

RS-232 Cable Pinouts

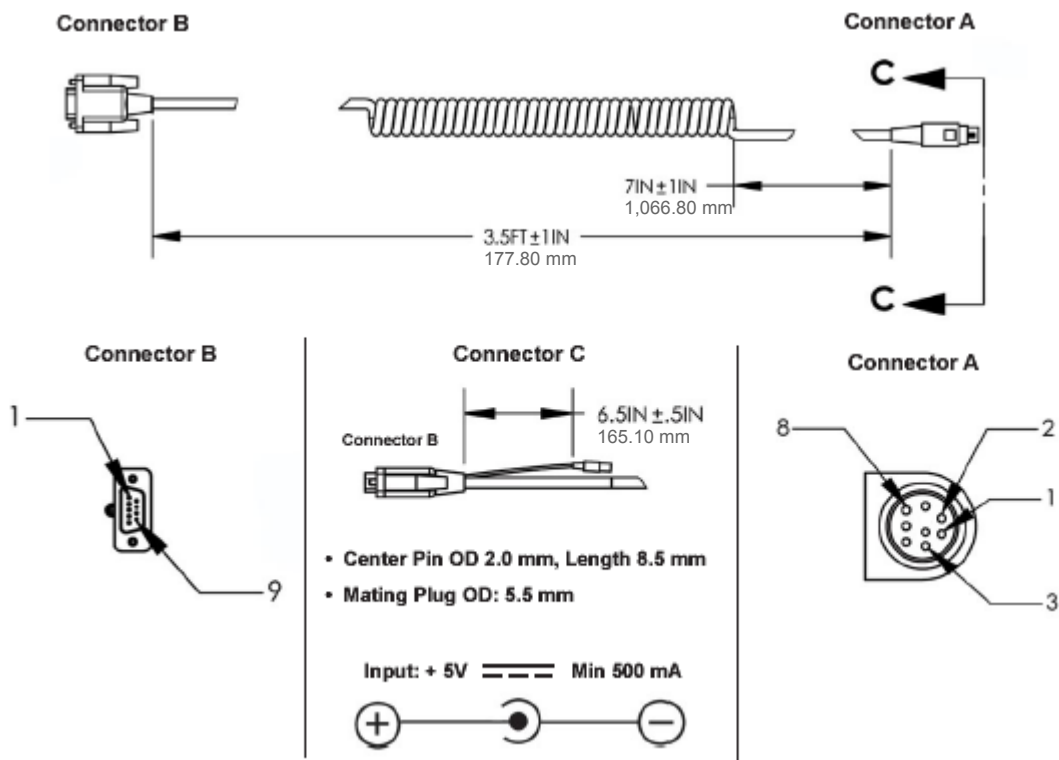

WIRING DIAGRAM:

CONN A	NAME	WIRE	COLOR	CONN B	WIRE	COLOR	CONN C
1	PWR	24AWG	RED	1	24AWG	RED	TIP
2	TX	28AWG	BROWN	2			
3	RX	28AWG	ORANGE	3			
4	NC						
5	NC						
6	NC						
7	NC						
8	GND	24AWG	BLACK	5	24AWG	BLACK	RING
9	NC						
SHELL	--	DRAIN	BARE	SHELL			

* SEE WIRING DIAGRAM BELOW FOR CONN A PIN 1, CONN B PIN 1 AND CONN C TIP

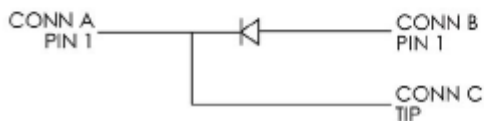

Appendix C — HS-2D Maintenance

HS-2D maintenance guidelines are provided below.

Cleaning the HS-2D Window

The HS-2D window should be clean to allow optimum performance. The window is the clear plastic piece inside the front of the reader. Do not touch the window, as fingerprints may impede decode performance. The HS-2D uses CMOS technology that is much like a digital camera, and marks on the window will interfere with image captures.

If the window becomes dirty, clean it with a soft, non-abrasive cloth or a facial tissue (no lotions or additives) that has been moistened with water. A mild detergent may be used to clean the window, but the window should be wiped with a water-moistened cloth or tissue after using the detergent. The HS-2D housing may be cleaned in the same way.

For applications that require cleaning with disinfectant, please use products with the following ingredients:

- Isopropyl Alcohol
- Ethyl Alcohol (Denatured Grade)

Do not use bleach.

