

## QX-830 Compact Industrial Scanner Transition Guide

The purpose of this document is to assist the user in transitioning from the **MS-820** to the **QX-830**.

MS-820 scanners have been used in a wide variety of applications, including food packaging, electronics manufacturing, automotive manufacturing, and other industrial environments. With the introduction of the **QX-830 Compact Industrial Scanner** and the **QX Platform**, applications that have used the MS-820 have the opportunity to simplify their connectivity, enhance their decode performance, and increase their configuration flexibility by upgrading to the new system.

The following procedure is a streamlined way of converting an application from the MS-820 to the QX-830.

1. Upgrade the version of **ESP Software** on the host computer to **ESP 5.0** or higher. ESP is available on the Microscan Tools CD and in the Download Center at [www.microscan.com](http://www.microscan.com).
2. Connect the **MS-820** to the host computer, open **ESP**, and **Receive Reader Settings** from the MS-820.

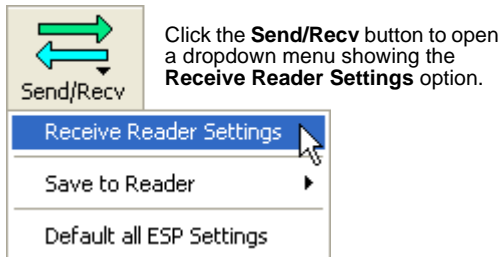

3. Navigate to the **Differences** tab in ESP's **Utilities** view and click the **Differences from Default** button. A list of commands will appear in a table below the Difference from Default button.

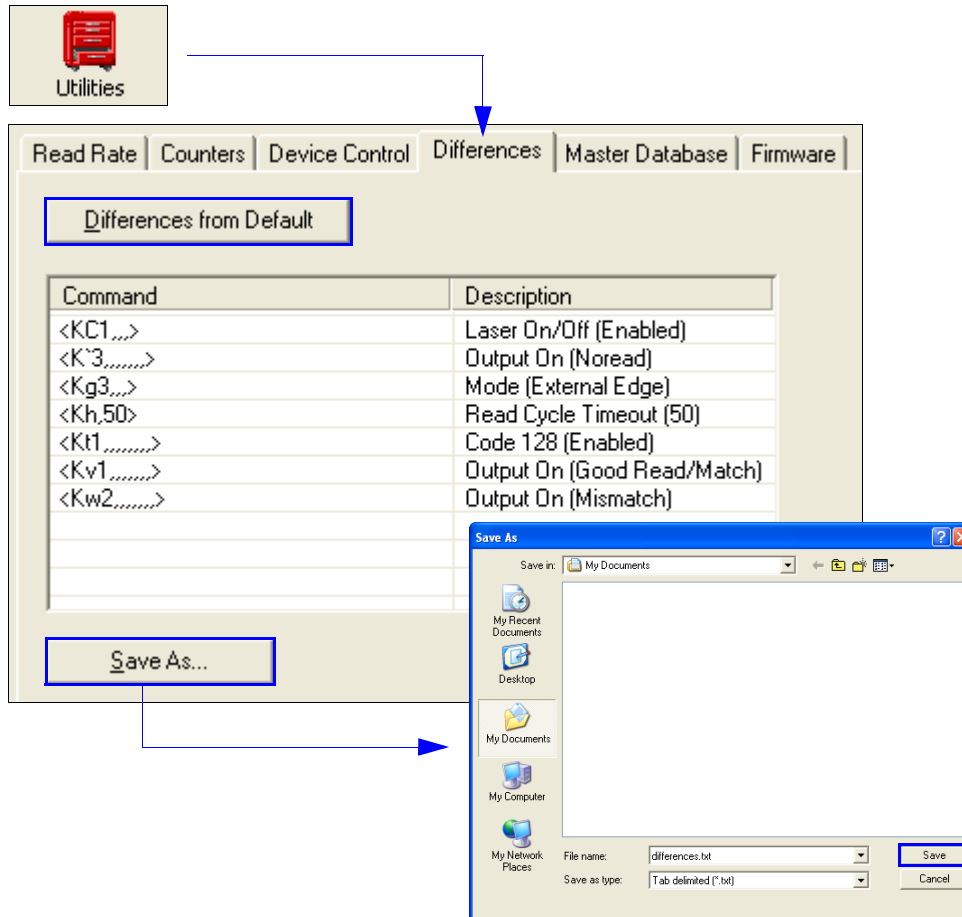

4. Click the **Save As** button below the Differences from Default command table, and select the **tab delimited (\*.txt)** file type when the Windows **Save As** dialog appears. Select the preferred location for the file on the host hard drive and click **Save**.

*QX-830 Compact Industrial Scanner Transition Guide*

- Remove power and physically disconnect the MS-820, physically connect the **QX-830**, reapply power, then **Switch Model** in ESP and select the QX-830 from the model menu.



- Autoconnect to the QX-830.



- Match the command settings in ESP's QX-830 tree controls to the list of commands in the tab delimited file that was created in Step 4. Refer to the [MS-820-to-QX-830 Command Conversions](#) table for a list of command equivalents between the MS-820 and QX-830.

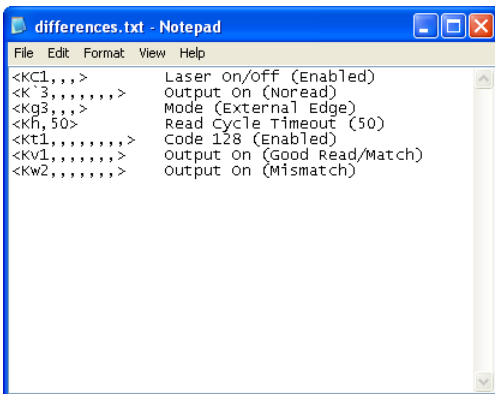

**Tab Delimited Text File with MS-820 Differences from Default Settings**

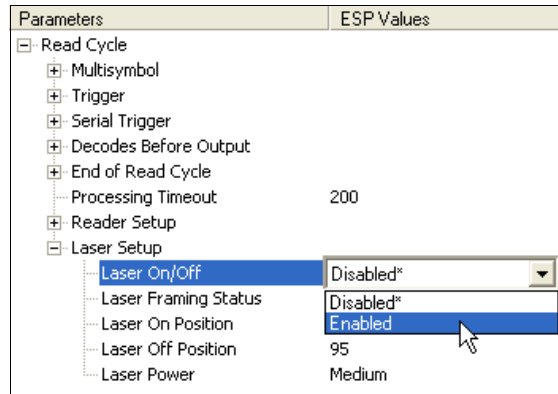

**QX-830 ESP Tree Control**

---

*QX-830 Compact Industrial Scanner Transition Guide*

- Once all the command settings shown in the tab delimited text file are matched in ESP's tree controls, **Send and Save** the settings to the QX-830.

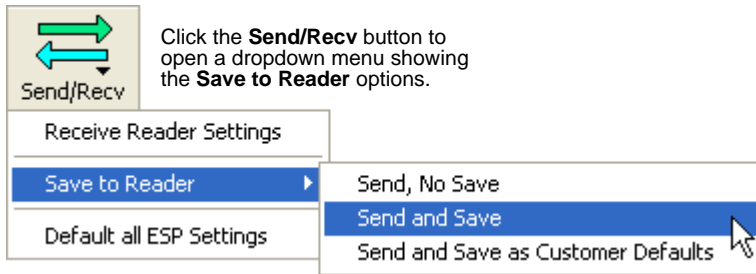

- Make additional configuration changes to the QX-830 as required by the application. Refer to the *QX-830 Compact Industrial Scanner User's Manual* for detailed information about scanner configuration.

For further assistance with any part of the MS-820 to QX-830 conversion process, contact the Microscan Help Desk:

helpdesk@microscan.com

+1.425.226.5700

## MS-820-to-QX-830 Command Conversions

The following table shows MS-820 commands on the left and QX-830 commands on the right. The name of the command is shown first, and the parameters are shown to the right of the name.

Commands whose parameters have remained exactly the same from MS-820 to QX-830 are shown directly opposite each other. Some MS-820 commands are not present in the QX-830, and some QX-830 commands are new. This is indicated with gray boxes. Similar commands are grouped closely where possible.

MS-820 Commands		QX-830 Commands	
<b>MS-820 Communications</b>		<b>QX-830 Communications</b>	
Host Port Connections	<K <b>a</b> baud rate,parity,stop bits,data bits>	RS-232 A	<K <b>100</b> ,baud rate,parity,stop bits,data bits>
Host Protocol	<K <b>f</b> protocol>		
RS-422 Status	<K <b>b</b> status>		
Auxiliary Port	<K <b>y</b> aux port mode,baud rate,parity,stop bits,data bits,daisy chain status,daisy chain ID>		
		RS-232 B	<K <b>101</b> ,status,baud rate,parity,stop bits,data bits>
		RS-422	<K <b>102</b> ,status,baud rate,parity,stop bits,data bits>
		Ethernet	<K <b>126</b> ,status,IP address,subnet,gateway,IP address mode>
		Ethernet TCP Ports	<K <b>127</b> ,TCP Port 1,TCP Port 2>
		EtherNet/IP	<K <b>129</b> ,status>
		RS-232 A Data Type	<K <b>130</b> ,symbol data output,extra symbol information,diagnostic output, external source processing mode>
		RS-232 B Data Type	<K <b>131</b> ,symbol data output,extra symbol information,diagnostic output, external source processing mode>
		RS-422 Data Type	<K <b>132</b> ,symbol data output,extra symbol information,diagnostic output, external source processing mode>
		Ethernet TCP Port 1 Data Type	<K <b>133</b> ,symbol data output,extra symbol information,diagnostic output, external source processing mode>
		Ethernet TCP Port 2 Data Type	<K <b>134</b> ,symbol data output,extra symbol information,diagnostic output, external source processing mode>
		EtherNet/IP Data Type	<K <b>136</b> ,symbol data output,extra symbol information,diagnostic output, external source processing mode>
		Preamble	<K <b>d</b> status,preamble>
		Postamble	<K <b>e</b> status,postamble>
Response Timeout	<K <b>A</b> response timeout>	Response Timeout	<K <b>143</b> ,response timeout>
LRC Status	<K <b>c</b> status>	LRC Status	<K <b>145</b> ,status>
		ACK/NAK Options	<K <b>147</b> ,RES,REQ,STX,ETX,ACK,NAK>
		Polling Mode Options	<K <b>148</b> ,RES,REQ,STX,ETX,ACK,NAK>
		Autoconfiguration Daisy Chain	<K <b>150</b> DAISY>
		Protocol Selection	<K <b>160</b> ,protocol,address,protocol port>
		External Data Routing	<K <b>161</b> ,mode,destination port,ambles to source,echo to source,output at end of read cycle,output at ETX,output at Timeout>
		Array Communication Modes	<K <b>162</b> ,mode,source,daisy chain i.d. status,daisy chain i.d.>
Intercharacter Delay	<K <b>B</b> intercharacter delay>		

QX-830 Compact Industrial Scanner Transition Guide

MS-820 Commands		QX-830 Commands	
		<b>QX-830 Calibration</b>	
		Auto Calibration Menu	<@>
		Auto Calibration without Menu	<@CAL>
<b>MS-820 Read Cycle</b>		<b>QX-830 Read Cycle</b>	
Trigger Mode	<Kg trigger mode, filter time>		
		Trigger Mode / Trigger Filter Duration	<K200, trigger mode, leading edge trigger filter duration, trailing edge trigger filter duration>
Serial Trigger Character	<Ki serial trigger character>	Serial Trigger Character	<K201, serial trigger character>
External Trigger State	<Kj external trigger state>	External Trigger State	<K202, external trigger state>
End of Read Cycle	<Kh mode, read cycle timeout>	End of Read Cycle	<K220, mode, read cycle timeout>
Good Decode Reads	<Km good decode reads>		
		Decodes Before Output	<K221, mode, number before output>
Multisymbol	<KL number of symbols, multisymbol separator>	Multisymbol	<K222, number of symbols, multisymbol separator>
		Serial Trigger Start Character	<K229, start character>
		Serial Trigger Stop Character	<K230, stop character>
		Processing Timeout	<K245, processing timeout>
Scan Speed	<KE scan speed>	Scan Speed	<K500, scan speed>
		Maximum Element	<K502, maximum element>
Automatic Gain Control	<KD AGC sampling mode, AGC min, AGC max>		
		Automatic Gain Control	<K504, gain level, AGC sampling mode, AGC minimum, AGC maximum>
Symbol Detect Status / Transition Counter	<KH symbol detect status, transition counter>	Symbol Detect Status / Transition Counter	<K505, symbol detect status, transition counter>
		Scan Width Enhance	<K511, status>
		AGC Tracking	<K520, tracking>
Scanner Type	<KP density>		
Laser Controls	<KC laser on/off, laser framing status, laser on position, laser off position>		
		Laser Setup	<K700, laser on/off, laser framing status, laser on position, laser off position, laser power>
		<b>QX-830 Configuration Database</b>	
		Number of Active Indexes	<K252, number of active indexes, number of database cycles>
		Configuration Database	<K253, index, gain, AGC mode, tracking, unused 1, unused 2, unused 3, framing status, laser on position, laser off position, laser power, background color>
		Switch Timing	<K254, switch mode, time>
<b>MS-820 Symbolologies</b>		<b>QX-830 Symbolologies</b>	
Narrow Margins / Symbology Identifier	<Ko narrow margins, symbology identifier status>		
		Quiet Zone	<K450, quiet zone status>
Background Color	<Kx background color>	Background Color	<K451, background color>
		Composite	<K453, symbology status, separator status, separator>

QX-830 Compact Industrial Scanner Transition Guide

MS-820 Commands		QX-830 Commands	
MS-820 Symbolologies (continued)		QX-830 Symbolologies (continued)	
AIAG	<KZ status, ID1, status1, ID2, status2, ID3, status3, ID4, status4, ID5a, ID5b, ID5c, status5, ID6, status6, ID7, status7, ID8, status8, ID9, status9, ID10, status10, ID11, status11, ID12, status12>	AIAG	<K454, status, ID1, status1, ID2, status2, ID3, status3, ID4, status4, ID5a, ID5b, ID5c, status5, ID6, status6, ID7, status7, ID8, status8, ID9, status9, ID10, status10, ID11, status11, ID12, status12>
		Depth of Field Enhance	<K456, DOF Enhance mode>
Code 39	<Kp status, check digit status, check digit output status, large intercharacter gap, fixed symbol length status, fixed symbol length, full ASCII set>	Code 39	<K470, status, check character status, check character output status, large intercharacter gap, fixed symbol length status, fixed symbol length, full ASCII set>
Codabar	<Kq status, start and stop match status, start and stop output status, large intercharacter gap, fixed symbol length status, symbol length, check digit type, check digit output>	Codabar	<K471, status, start/stop match status, start/stop output status, large intercharacter gap, fixed symbol length status, fixed symbol length, check character type, check character output status>
Interleaved 2 of 5	<Kr status, check digit status, check digit output, symbol length 1, symbol length 2>	Interleaved 2 of 5	<K472, status, check character status, check character output status, symbol length 1, symbol length 2, guard bar, range mode status>
UPC/EAN	<Ks UPC status, EAN status, supplementals status, separator status, separator character>	UPC/EAN	<K473, mode, EAN status, supplementals status, separator status, separator character, supplementals type, UPC-E as UPC-A>
Code 128 / EAN 128	<Kt status, fixed symbol length status, fixed symbol length, EAN-128 status, output format, application record separator status, application record separator character, application record brackets, application record padding>	Code 128 / EAN 128	<K474, status, fixed symbol length status, fixed symbol length, EAN status, output format, application record separator status, application record separator character, application record brackets, application record padding, separation factor>
Code 93	<Kl status, fixed symbol length status, symbol length>	Code 93	<K475, mode, fixed symbol length status, symbol length>
PDF417	<Kl status, raster sweeps before decode attempt, fixed length status, symbol length>	PDF417	<K476, status, scan line limit, fixed symbol length status, fixed symbol length, decode at end of read cycle>
		Pharmacode	<K477, status, fixed bar count status, fixed bar count, minimum bar count, bar width mode, direction, fixed threshold value>
		DataBar Omnidirectional (RSS-14)	<K482, status>
		DataBar Limited (RSS Limited)	<K483, status>
		DataBar Expanded (RSS Expanded)	<K484, status, fixed symbol length status, fixed symbol length>
		MicroPDF417	<K485, status, scan line limit, fixed symbol length status, fixed symbol length>
		Symbol Reconstruction	<K496, symbol reconstruction redundancy, symbol reconstruction effort>
MS-820 I/O Parameters		QX-830 I/O Parameters	
		Calibration Options	<K521, unused, video, scan speed, laser power, laser framing, symbology>
Serial Verification	<KS command echo status, command beep status, control/hex output>	Serial Verification	<K701, serial command echo status, serial command beep status, control/hex output>
Beeper	<Ku status, volume>	Beeper	<K702, status>
		Quality Output	<K704, quality output separator, decodes/trigger status, decode direction output>

QX-830 Compact Industrial Scanner Transition Guide

MS-820 Commands		QX-830 Commands	
<b>MS-820 I/O Parameters (continued)</b>		<b>QX-830 I/O Parameters (continued)</b>	
Symbol Data Output	<Kl symbol data output status, when to output>		
		Symbol Data Output	<K705, symbol data output status, when to output symbol data, symbology identifier status>
		Read Duration Output	<K706, status, separator>
No Read Message	<Kk status, message>	No Read Message	<K714, status, message>
Bad Symbol Message	<KM status, message>	Bad Symbol Message	<K715, status, message>
No Symbol Message	<KN status, message>	No Symbol Message	<K716, status, message>
		Input 1	<K730, input mode, active state>
No Object Message	<KO status, message>		
Laser On / Off Status	<KC laser on/off status>		
Partial Output	<KY status, start position, length>		
		Green Flash LED	<K750, green flash mode, unused, green flash duration>
		Status Indicators	<K751, status, bar graph, I/O 1, I/O 2>
		Symbol Position Output	<K758, scan status, separator>
		Database Identifier Output	<K759, status, separator character>
		EZ Button	<K770, status, default on power-on>
		EZ Button Modes	<K771, single beep, two beeps, three beeps, four beeps>
		Auto Framing Options	<K773, laser framing>
Output 1	<Kv output on, active state, pulse width, output mode, trend analysis mode, trigger evaluation period, number to output on, reads per trigger threshold>		
Output 2	<Kw output on, active state, pulse width, output mode, trend analysis mode, trigger evaluation period, number to output on, reads per trigger threshold>		
Output 3	<K' output on, active state, pulse width, output mode, trend analysis mode, trigger evaluation period, number to output on, reads per trigger threshold>		
		Trend Analysis Output 1	<K780, trend analysis mode, number of triggers, number to output on, decodes per trigger>
		Trend Analysis Output 2	<K781, trend analysis mode, number of triggers, number to output on, decodes per trigger>
		Trend Analysis Output 3	<K782, trend analysis mode, number of triggers, number to output on, decodes per trigger>
		Diagnostics Output 1	<K790, high temperature, service unit, unused, laser current high, laser current low, low temperature>
		Diagnostics Output 2	<K791, high temperature, service unit, unused, laser current high, laser current low, low temperature>
		Diagnostics Output 3	<K792, high temperature, service unit, unused, laser current high, laser current low, low temperature>
		Output 1 Parameters	<K810, output on, output state, pulse width, output mode>
		Output 2 Parameters	<K811, output on, output state, pulse width, output mode>

QX-830 Compact Industrial Scanner Transition Guide

MS-820 Commands		QX-830 Commands	
<b>MS-820 I/O Parameters (continued)</b>		<b>QX-830 I/O Parameters (continued)</b>	
		Output 3 Parameters	<K812,output on,output state,pulse width,output mode>
<b>MS-820 Matchcode</b>		<b>QX-830 Matchcode</b>	
Matchcode	<K $n$ matchcode type,sequential matching,match start position,match length,wild card character,sequence on noread,sequence on mismatch>	Matchcode	<K223,matchcode type,sequential matching,match start position,match length,wild card,sequence on no read,sequence on mismatch>
Master Symbol Database Size	<KMnumber of master symbols>	Master Symbol Database Size	<K224,number of master symbols>
New Master Pin	<Kzstatus>	New Master Pin	<K225,status>
		Sequence Step	<K228,sequence step>
		Master Symbol	<K231,index,master symbol data>
		Match Replace	<K735,status,replacement string>
		Mismatch Replace	<K736,status,replacement string>
<b>MS-820 Diagnostics</b>		<b>QX-830 Diagnostics</b>	
High Temperature Threshold	<K+degrees,message>		
Low Temperature Threshold	<K-degrees,message>		
		High Temperature Threshold	<K402,status,message>
		Low Temperature Threshold	<K403,status,message>
Counts (Read-only)	<K_?> (returns: power-ons,resets)		
		Counts (Read-only)	<K406> (returns: power-on,resets, power-on saves,custom default saves)
Hours Since Reset (Read-only)	<K@?> (returns: hours,minutes)	Hours Since Reset (Read-only)	<K407> (returns: hours,minutes)
Warning Message Status	<K" warning message status,laser high status,laser low status,NOVRAM corrupt warning status>		
		Service Message	<K409,status,service message, threshold,resolution>
Laser High Warning	<K;laser high message>		
Laser Low Warning	<K:laser low message>		
		Laser Current Warning Message	<K411,laser high status,laser high message,laser low status,laser low message>
Present Operating Temperature	<K%?> (returns: degrees Celsius)		
Lifetime Hours	<K\$hours10,message>		
		User-Defined Name	<K412,user-defined name>
		<b>QX-830 Output Format</b>	
		Format Extract	<K740,output index,start location,length>
		Format Insert	<K741,output index,length,hex string>
		Format Assign	<K742,symbol number,status>
		Format Status	<K743,output format status>
		Output Filter Configuration	<K744,filter number,symbology,length,wildcard,placeholder,data,unused,database index>
		Output Filter Enable	<K745,number of filters>



## MS-820 and QX-830 Connectivity

There are significant hardware and connectivity differences between the MS-820 and QX-830. The diagrams and parts lists below demonstrate the difference between MS-820 and QX-830 hardware configuration.

**Note:** For other configurations, such as multidrop and daisy chain, refer to the configuration guides and user's manuals for the MS-820 and QX-830.

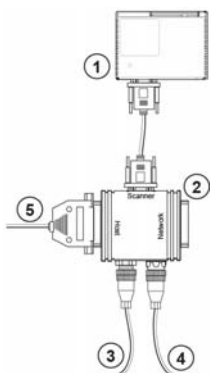

**MS-820 Standalone with IB-131**

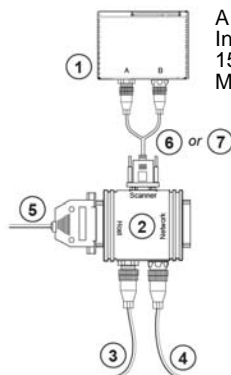

**QX-830 Standalone with IB-131**

A QX-830 can be connected to an IB-131 Interface Box using the RS-232 M12 to 15-pin Dsub cordset (6) or the RS-422/485 M12 to 15-pin Dsub cordset (7).

Item	Description	Part Number
1	MS-820 Industrial Laser Scanner	FIS-0820-XXXXG
2	IB-131 Kit, Interface Box and IB-131 cable, 6 ft.	98-000014-02
3	Power Supply, 90-264 VAC, 24VDC, USA/Euro plug	97-100004-15
4	Object Detector Photo Sensor, Visible, NPN, Dark On	99-000017-01
5	Communication Cable, 25-pin plug to 9-pin socket, 6 ft.	61-300026-03
6	QX Cordset, M12 12-pin plug and M12 12-pin socket to IB-131 (RS-232), 2 m	61-000159-01
7	QX Cordset, M12 12-pin plug and M12 12-pin socket to IB-131 (RS-422/485), 2 m	61-000159-02

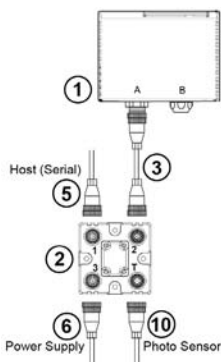

**QX-830 Serial Standalone with QX-1**

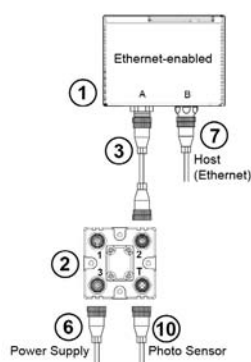

**QX-830 Ethernet Standalone with QX-1**

Item	Description	Part Number
1	QX-830 Compact Industrial Scanner	FIS-0830-XXXXG
2	QX-1 Interface Device	98-000103-01
3	QX Cordset, Common, M12 12-pin Plug to M12 12-pin Socket, 1 m	61-000162-01
4	QX Cordset, Host, Serial, M12 12-pin Plug to DB9, 1 m (not shown)	61-000152-01
5	QX Cordset, Host, Serial, M12 12-pin Socket to DB9, 1 m	61-000153-01
6	QX Power Supply, M12 12-pin Socket, 1.3 m	97-000003-01
7	QX Cordset, Host, Ethernet, M12 8-pin Plug to RJ45, 1 m	61-000160-01
8	QX Cordset, M12 12-pin Plug to MS-Connect 5100, 3 m (not shown)	61-000161-01
9	QX Cordset, M12 12-pin Plug / M12 12-pin Socket to MS-Connect 210, RS-232, 2 m (not shown)	61-000158-01
10	QX Photo Sensor, M12 4-pin Plug, NPN, Dark On, 2 m	99-000020-02

## MS-820 and QX-830 Specifications

Only specifications that have changed from the MS-820 to the QX-830 are shown below.

### Mechanical

The mounting dimensions of the MS-820 and QX-830 are essentially the same, although the M12 receptacles at the back of the QX-830 may affect installation in some applications.

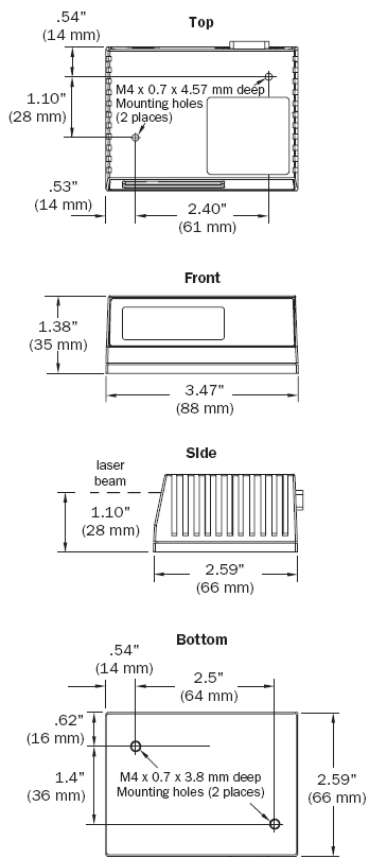

MS-820 Dimensions

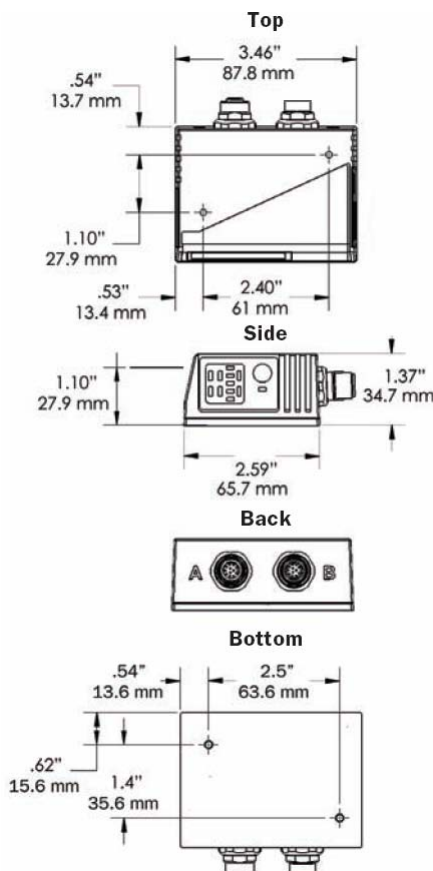

QX-830 Dimensions

### Environmental

MS-820		QX-830	
Storage Temperature	-50° to 75° C (-58° to 167° F)	Storage Temperature	-29° to 70° C (-20° to 158° F)

### Emissions

MS-820		QX-830	
Heavy industrial	EN 61000-6:1999	Heavy industrial	EN 61000-6-2:2005
Radiated emissions	EN 55022:1998 Class A 30-1000 MHz	Radiated emissions	EN 55022:2006 Class A 30-1000 MHz
Conducted emissions	EN 55022:1998 Class A .15-30 MHz	Conducted emissions	EN 55022:2006 Class A .15-30 MHz

### Laser Light

MS-820		QX-830	
Output Wavelength	650 nm nominal (MS-825 infrared option: 780 nm nominal)	Output Wavelength	655 nm nominal
Safety Class	Visible laser: CDRH Class II, 650 nm; Infrared Laser: CDRH Class I, 780 nm	Safety Class	Visible laser: CDRH Class II, 655 nm

### Scanning Parameters

MS-820		QX-830	
Scan Rate	Adjustable from 350 to 1100 scans per second	Scan Rate	Adjustable from 300 to 1400 scans per second
Symbol Contrast	25% min. absolute dark to light differential at 650 nm wavelength.	Symbol Contrast	25% min. absolute dark to light differential at 655 nm wavelength.

### Communication Interface

MS-820		QX-830	
Interfaces	RS-232, RS-422, RS-485	Interfaces	RS-232, RS-422, RS-485, Ethernet

### Protocols

MS-820		QX-830	
Protocols	Point-to-Point, Point-to-Point with RTS/CTS, Point-to-Point with XON/XOFF, Point-to-Point with RTS/CTS and XON/XOFF, Polling Mode D, Multidrop, Daisy Chain, User-Defined, User-Defined Multidrop	Protocols	Point-to-Point, Point-to-Point with RTS/CTS, Point-to-Point with XON/XOFF, Point-to-Point with RTS/CTS and XON/XOFF, Multidrop, Daisy Chain, User-Defined Multidrop, Ethernet TCP/IP, EtherNet/IP

### Symbologies

MS-820		QX-830	
Symbologies	<b>Standard Offering:</b> Code 39, Codabar, Code 93, Interleaved 2 of 5, Code 128, PDF417, Pharmacode (optional). <b>Applications Standards:</b> EAN-128, AIAG	Symbologies	<b>Standard Offering:</b> Code 39, Codabar, Code 93, Interleaved 2 of 5, Code 128, PDF417, MicroPDF417, Pharmacode, UPC, GS1 DataBar. <b>Applications Standards:</b> EAN-128, AIAG

### Electrical

MS-820		QX-830	
Power Requirement	10-28VDC, 200 mV p-p max. ripple, 120mA at 24VDC (typ.)	Power Requirement	10-28VDC, 200 mV p-p max. ripple, 180mA at 24VDC (typ.)

### MS-820 Pin Assignments

Pin No.	Host RS-232	Host/Aux. RS-232	Host RS-422/485	In/Out
1	Power +10 to 28VDC			In
2	TxD	TxD	TxD (-)	Out
3	RxD	RxD	RxD (-)	In
4	Power/Signal Ground			
5	Trigger (-)			In
6	RTS	Aux TxD	TxD (+)	Out
7	Output 1 (+)			Out
8	Default Configuration (Connect Pin 8 to Ground Pin 4)			In
9	Trigger (+)			In
10	CTS	Aux RxD	RxD (+)	In
11	Output 3 (+)			Out
12	New Master (+)			In
13	Chassis Ground (Used to connect chassis body to earth Ground only. Not to be used as power or signal return.)			
14	Output 2 (+)			Out
15	Outputs 1, 2, 3 (-)			Out

## QX-830 Pin Assignments

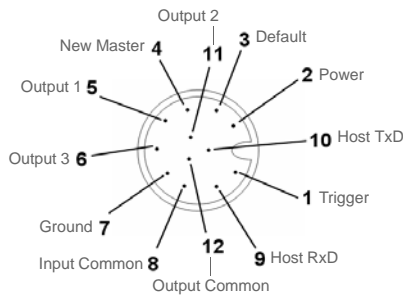

**Connector A (Serial)  
M12 12-pin Plug**

9	Host RxD
10	Host TxD
2	Power
7	Ground
1	Trigger
8	Input Common
3	Default
4	New Master
5	Output 1
11	Output 2
6	Output 3
12	Output Common

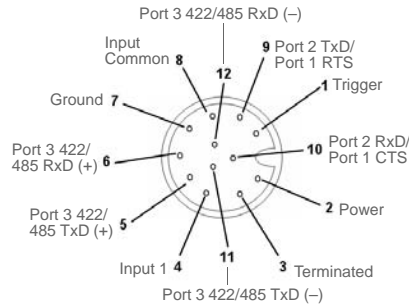

**Connector B (Serial)  
M12 12-pin Socket**

9	Port 2 TxD/Port 1 RTS
10	Port 2 RxD/Port 1 CTS
2	Power
7	Ground
1	Trigger
8	Input Common
3	Terminated
4	Input 1
5	Port 3 422/485 TxD (+)
11	Port 3 422/485 TxD (-)
6	Port 3 422/485 RxD (+)
12	Port 3 422/485 RxD (-)

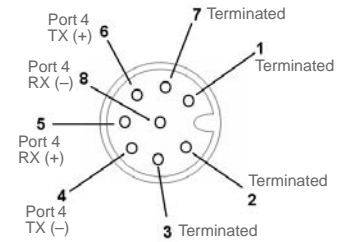

**Connector B (Ethernet)  
M12 8-pin Socket**

1	Terminated
2	Terminated
3	Terminated
4	Port 4 TX (-)
5	Port 4 RX (+)
6	Port 4 TX (+)
7	Terminated
8	Port 4 RX (-)

### Discrete I/O

MS-820		QX-830	
Trigger Input	Optoisolated, 4.5–28V rated (12 mA at 24VDC)	Input 1 (Trigger / New Master)	Optoisolated, 4.5–28V rated (13 mA at 24VDC); New Master is (-) to signal ground
New Master Input	Optoisolated, 4.5–28V rated (12 mA at 24VDC), New Master (-) to signal ground		

### Safety Certifications

MS-820		QX-830	
Certifications	CDRH, FCC, UL/cUL, CE, BSMI	Certifications	CDRH, FCC, UL/cUL, CE, CB, BSMI